

CATALOG NO. 6695 60
JUNE 1999

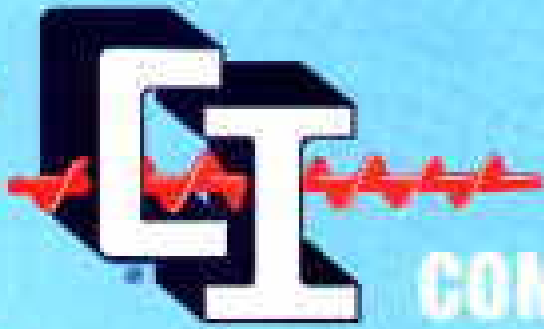

CONVEYORS, INC.

**SCREW
CONVEYOR
ENGINEERING
GUIDE**

CONVEYORS, INC. IS NOT RESPONSIBLE
FOR ANY DAMAGE TO YOUR EQUIPMENT
OR PERSONS OR PROPERTY.

P.O. BOX 30817
FORT WORTH, TEXAS 76185
PHONE 817/473-4645
FAX # 817/473-3024
www.conveyorsinc.net



Contents

Introduction	1
---------------------------	----------

Engineering

Materials Characteristics Chart	2
Material Classification Code Chart	11
Component Group Selection Guide Chart	12
Conveyor Capacity	13
Horsepower	15
Components Groups Chart	17
Comparison Table	18

Components

Conveyor Screws	19
Conveyor Screw Components	28
Shafts	29
Hangers	31
Hanger Bearings	37
Trough Ends	38
Trough End Bearings	46
Thrust Bearings	47
Shaft Seals	49
Troughs	51
Trough Flanges	54
Trough Saddles & Feet	56
Discharge Spouts & Gates	57
Trough Covers & Accessories	62
Bolt Patterns	64
Safety / Installation and Maintenance Instructions	66
Screw Layout / Hand of Conveyor	70
Design Info Sheet	71

INTRODUCTION



MANY BULK MATERIALS ARE HANDLED EASILY AND EFFICIENTLY IN SCREW CONVEYORS OR FEEDERS. HOWEVER, TO INSURE THE BEST POSSIBLE SELECTION OF COMPONENTS, IT IS RECOMMENDED THAT CONSIDERATION BE GIVEN TO THE PHYSICAL, CHEMICAL AND HANDLING CHARACTERISTICS OF ALL MATERIALS.

THE ESSENTIAL CHARACTERISTICS INCLUDE SIZE, FLOWABILITY AND ABRASIVENESS, OF THE MATERIALS. OTHER CHARACTERISTICS, SUCH AS CONTAMINATION, CORROSIVENESS, DEGRADABILITY, FLUFFINESS, ETC. MAY INFLUENCE THE HANDLING AND SHOULD BE GIVEN TO MATERIALS WHICH MAY ASSUME DIFFERENT CHARACTERISTICS UNDER CERTAIN CONDITIONS OF PROCESSING, ATMOSPHERE, AGE OR STORAGE.

THE ENGINEERING INFORMATION PRESENTED IN THIS SECTION HAS BEEN COMPILED FROM THE MANY YEARS OF EXPERIENCE IN THE SUCCESSFUL DESIGN AND APPLICATION OF NUMEROUS AND VARIED SCREW CONVEYOR AND SCREW FEEDER INSTALLATIONS.

SUFFICIENT INFORMATION IS AVAILABLE TO EASILY SELECT THE COMPONENTS RECOMMENDED FOR HANDLING MATERIALS UNDER NORMAL OPERATING CONDITIONS IN HORIZONTAL SCREW CONVEYORS AND FEEDERS.

IT IS SINCERELY HOPED THAT YOU WILL FIND THIS ENGINEERING GUIDE COMPLETE IN DETAIL, EASY TO USE AND EXTREMELY HELPFUL IN CREATING NEW AND IMPROVED SOLUTIONS TO YOUR CONVEYING PROBLEMS. WHERE UNUSUAL APPLICATIONS OR SEVERE OPERATING CONDITIONS ARE A FACTOR OR WHERE THERE MAY BE DOUBT AS TO THE CORRECT SELECTION OF SCREW CONVEYORS OR SCREW FEEDERS, CONSULT CONVEYORS, INC.

MATERIAL CHARACTERISTICS CHART

Material	Weight lbs. per cu. ft.	Material Code	Component Series	Mat'l. Factor Fm	Conv. Loading %
Adipic Acid	45	45A ₁₀₀ ³⁵	2B	.5	30A
Alfalfa Meal	14-22	18B ₆ ^{45WY}	2D	.9	30A
Alfalfa Pellets	41-43	42C _{1/2} ²⁵	2D	.5	45
Alfalfa Seed	10-15	13B ₆ ^{15N}	1A-1B-1C	.4	45
Almonds, Broken	27-30	29C _{1/2} ^{35Q}	2D	.9	30A
Almonds, Whole Shelled	28-30	29C _{1/2} ^{35Q}	2D	.9	30A
Alum, Fine	45-50	48B ₆ ^{35U}	1A-1B-1C	.6	30A
Alum, Lumpy	50-60	55B ₆ ²⁵	2A-2B	1.4	45
Alumina	55-65	58B ₆ ^{27MY}	3D	1.8	15
Alumina Fines	35	35A ₁₀₀ ^{27MY}	3D	1.6	15
Alumina Sized or Briquette	65	65D ₃ ³⁷	3D	2.0	15
Aluminate Gel (Aluminate Hydroxide)	45	45B ₆ ³⁵	2D	1.7	30A
Aluminum Chips, Dry	7-15	11E ^{45V}	2D	1.2	30A
Aluminum Chips, Oily	7-15	11E ^{45V}	2D	.8	30A
Aluminum Hydrate	13-20	17C _{1/2} ³⁵	1A-1B-1C	1.4	30A
Aluminum Ore (See Bauxite)	—	—	—	—	—
Aluminum Oxide	60-120	90A ₁₀₀ ^{17M}	3D	1.8	15
Aluminum Silicate (Andalusite)	49	49C _{1/2} ^{35S}	3A-3B	.8	30A
Aluminum Sulfate	45-58	52C _{1/2} ²⁵	1A-1B-1C	1.0	45
Ammonium Chloride, Crystalline	45-52	49A ₁₀₀ ^{45FRS}	3A-3B	.7	30A
Ammonium Nitrate	45-62	54A ₄₀ ^{35NTU}	3B	1.3	30A
Ammonium Sulfate	45-58	52C _{1/2} ^{35FOTU}	1A-1B-1C	1.0	30A
Antimony Powder	—	A ₁₀₀ ³⁵	2D	1.6	30A
Apple Pomace, Dry	15	15C _{1/2} ^{45Y}	2D	1.0	30A
Arsenate of Lead (See Lead Arsenate)	—	—	—	—	—
Arsenic Oxide (Arsenolite)*	100-120	110A ₁₀₀ ^{35R}	—	—	30A
Arsenic Pulverized	30	30A ₁₀₀ ^{25R}	2D	.8	45
Asbestos-Rock (Ore)	81	81D ₃ ^{37R}	3D	1.2	15
Asbestos-Shredded	20-40	30E ^{46XY}	2D	1.0	30B
Ash, Black Ground	105	105B ₆ ³⁵	1A-1B-1C	2.0	30A
Ashes, Coal, dry—1/2"	35-45	40C _{1/2} ^{46TY}	3D	4.0	30B
Ashes, Coal, dry—3"	35-40	38D ₃ ^{46T}	3D	4.0	30B
Ashes, Coal, wet—1/2"	45-50	48C _{1/2} ^{46T}	3D	5.0	30B
Ashes, Coal, wet—3"	45-50	48D ₃ ^{46T}	3D	5.0	30B
Ashes, Fly (See Fly Ash)	—	—	—	—	—
Asphalt, Crushed—1/2"	45	45C _{1/2} ⁴⁵	1A-1B-1C	2.0	30A
Bagasse	7-10	9E ^{45RVXY}	2A-2B-2C	1.5	30A
Bakelite, Fine	30-45	38B ₆ ²⁵	1A-1B-1C	1.4	45
Baking Powder	40-55	48A ₁₀₀ ³⁵	1B	.6	30A
Baking Soda (Sodium Bicarbonate)	40-55	48A ₁₀₀ ²⁵	1B	.6	45
Barite (Barium Sulfate) + 1/2"—3"	120-180	150D ₃ ³⁶	3D	2.6	30B
Barite, Powder	120-180	150A ₁₀₀ ^{35X}	2D	2.0	30A
Barium Carbonate	72	72A ₁₀₀ ^{45R}	2D	1.6	30A
Bark, Wood, Refuse	10-20	15E ^{45TVY}	3D	2.0	30A
Barley, Fine, Ground	24-38	31B ₆ ³⁵	1A-1B-1C	.4	30A
Barley, Malted	31	31C _{1/2} ³⁵	1A-1B-1C	.4	30A
Barley, Meal	28	28C _{1/2} ³⁵	1A-1B-1C	.4	30A
Barley, Whole	36-48	42B ₆ ^{25N}	1A-1B-1C	.5	45
Basalt	80-105	93B ₆ ²⁷	3D	1.8	15
Bauxite, Dry, Ground	68	68B ₆ ²⁵	2D	1.8	45
Bauxite, Crushed—3"	75-85	80D ₃ ³⁶	3D	2.5	30B
Beans, Castor, Meal	35-40	38B ₆ ^{35W}	1A-1B-1C	1.2	30A
Beans, Castor, Whole Shelled	36	36C _{1/2} ^{15W}	1A-1B-1C	.5	45
Beans, Navy, Dry	48	48C _{1/2} ¹⁵	1A-1B-1C	.5	45
Beans, Navy, Steeped	60	60C _{1/2} ²⁵	1A-1B-1C	.8	45

MATERIAL CHARACTERISTICS CHART (cont'd)

Material	Weight lbs. per cu. ft.	Material Code	Component Series	Mat'l. Factor Fm	Conv. Loading %
Bentonite, Crude	34-40	37D ₃ 45X	2D	1.2	30A
Bentonite,—100 Mesh	50-60	55A ₁₀₀ 25MXY	2D	.7	45
Benzene Hexachloride	56	56A ₁₀₀ 45R	1A-1B-1C	.6	30A
Bicarbonate of Soda (Baking Soda)	—	—	1B	.6	45
Blood, Dried	35-45	40D ₃ 45U	2D	2.0	30A
Blood, Ground, Dried	30	30A ₁₀₀ 35U	1A-1B	1.0	30A
Bone Ash (Tricalcium Phosphate)	40-50	45A ₁₀₀ 45	1A-1B	1.6	30A
Boneblack	20-25	23A ₁₀₀ 25Y	1A-1B	1.7	45
Bonechar	27-40	34B ₆ 35	1A-1B	1.7	30A
Bonemeal	50-60	55B ₆ 35	2D	1.7	30A
Bones, Whole*	35-50	43E45V	2D	3.0	30A
Bones, Crushed	35-50	43D ₃ 45	2D	2.0	30A
Bones, Ground	50	50B ₆ 35	2D	1.7	30A
Borate of Lime	60	60A ₁₀₀ 35	1A-1B-1C	.6	30A
Borax, Fine	45-55	50B ₆ 25T	3D	.7	45
Borax Screening—1/2"	55-60	58C _{1/2} 35	2D	1.5	30A
Borax, 1-1/2 - 2" Lump	55-60	58D ₃ 35	2D	1.8	30A
Borax, 2" - 3" Lump	60-70	65D ₃ 35	2D	2.0	30A
Boric Acid, Fine	55	55B ₆ 25T	3D	.8	45
Boron	75	75A ₁₀₀ 37	2D	1.0	15
Bran, Rice-Rye-Wheat	16-20	18B ₆ 35NY	1A-1B-1C	.5	30A
Braunite (Manganese Oxide)	120	120A ₁₀₀ 36	2D	2.0	30B
Bread Crumbs	20-25	23B ₆ 35PQ	1A-1B-1C	.6	30A
Brewer's Grain, spent, dry	14-30	22C _{1/2} 45	1A-1B-1C	.5	30A
Brewer's Grain, spent, wet	55-60	58C _{1/2} 45T	2A-2B	.8	30A
Brick, Ground—1/8"	100-120	110B ₆ 37	3D	2.2	15
Bronze Chips	30-50	40B ₆ 45	2D	3.0	30A
Buckwheat	37-42	40B ₆ 25N	1A-1B-1C	.4	45
Calcine, Flour	75-85	80A ₁₀₀ 35	1A-1B-1C	.7	30A
Calcium Carbide	70-90	80D ₃ 25N	2D	2.0	30A
Calcium Carbonate (See Limestone)	—	—	—	—	—
Calcium Fluoride (See Fluorspar)	—	—	—	—	—
Calcium Hydrate (See Lime, Hydrated)	—	—	—	—	—
Calcium Hydroxide (See Lime, Hydrated)	—	—	—	—	—
Calcium Lactate	26-29	28D ₃ 45QTR	2A-2B	.6	30A
Calcium Oxide (See Lime, unslaked)	—	—	—	—	—
Calcium Phosphate	40-50	45A ₁₀₀ 45	1A-1B-1C	1.6	30A
Calcium Sulfate (See Gypsum)	—	—	—	—	—
Carbon, Activated, Dry, Fine*	—	—	—	—	—
Carbon Black, Pelleted*	—	—	—	—	—
Carbon Black, Powder*	—	—	—	—	—
Carborundum	100	100D ₃ 27	3D	3.0	15
Casein	36	36B ₆ 35	2D	1.6	30A
Cashew Nuts	32-37	35C _{1/2} 45	2D	.7	30A
Cast Iron, Chips	130-200	165C _{1/2} 45	2D	4.0	30A
Caustic Soda	88	88B ₆ 35RSU	3D	1.8	30A
Caustic Soda, Flakes	47	47C _{1/2} 45RSUX	3A-3B	1.5	30A
Celite (See Diatomaceous Earth)	—	—	—	—	—
Cement, Clinker	75-95	85D ₃ 36	3D	1.8	30B
Cement, Mortar	133	133B ₆ 35Q	3D	3.0	30A
Cement, Portland	94	94A ₁₀₀ 26M	2D	1.4	30B
Cement, Aerated (Portland)	60-75	68A ₁₀₀ 16M	2D	1.4	30B
Cerrusite (See Lead Carbonate)	—	—	—	—	—
Chalk, Crushed	75-95	85D ₃ 25	2D	1.9	45
Chalk, Pulverized	67-75	71A ₁₀₀ 25MXY	2D	1.4	45

MATERIAL CHARACTERISTICS CHART (cont'd)

Material	Weight lbs. per cu. ft.	Material Code	Component Series	Mat'l. Factor Fm	Conv. Loading %
Charcoal, Ground	18-28	23A ₁₀₀ ⁴⁵	2D	1.4	30A
Charcoal, Lumps	18-28	23D ₃ ^{45Q}	2D	1.4	30A
Chocolate, Cake Pressed	40-45	43D ₃ ²⁵	2B	1.5	45
Chrome Ore	125-140	133D ₃ ³⁶	3D	2.5	30B
Cinders, Blast Furnace	57	57D ₃ ^{36T}	3D	1.9	30B
Cinders, Coal	40	40D ₃ ^{36T}	3D	1.8	30B
Clay (See Bentonite, Diatomaceous Earth, Fuller's Earth, Kaolin & Marl)	—	—	—	—	—
Clay, Ceramic, Dry, Fines	60-80	70A ₁₀₀ ^{35P}	1A-1B-1C	1.5	30A
Clay, Calcined	80-100	90B ₆ ³⁶	3D	2.4	30B
Clay, Brick, Dry, Fines	100-120	110C _{1/2} ³⁶	3D	2.0	30B
Clay, Dry, Lumpy	60-75	68D ₃ ³⁵	2D	1.8	30A
Clinker, Cement (See Cement Clinker)	—	—	—	—	—
Clover Seed	45-48	47B ₆ ^{25N}	1A-1B-1C	.4	45
Coal, Anthracite (River & Culm)	55-61	60B ₆ ^{35TY}	2A-2B	1.0	30A
Coal, Anthracite, Sized—1/2"	49-61	55C _{1/2} ²⁵	2A-2B	1.0	45
Coal, Bituminous, Mined	40-60	50D ₃ ^{35LNXY}	1A-1B	.9	30A
Coal, Bituminous, Mined, Sized	45-50	48D ₃ ^{35QV}	1A-1B	1.0	30A
Coal, Bituminous, Mined, Slack	43-50	47C _{1/2} ^{45T}	2A-2B	.9	30A
Coal, Lignite	37-45	41D ₃ ^{35T}	2D	1.0	30A
Cocoa Beans	30-45	38C _{1/2} ^{25Q}	1A-1B	.5	45
Cocoa, Nibs	35	35C _{1/2} ²⁵	2D	.5	45
Cocoa, Powdered	30-35	33A ₁₀₀ ^{45XY}	1B	.9	30A
Cocanut, Shredded	20-22	21E ⁴⁵	2B	1.5	30A
Coffee, Chaff	20	20B ₆ ^{25MY}	1A-1B	1.0	45
Coffee, Green Bean	25-32	29C _{1/2} ^{25PQ}	1A-1B	.8	45
Coffee, Ground, Dry	25	25A ₄₀ ^{35P}	1A-1B	.6	30A
Coffee, Ground, Wet	35-45	40A ₄₀ ^{45X}	1A-1B	.6	30A
Coffee, Roasted Bean	20-30	25C _{1/2} ^{25PQ}	1B	.4	45
Coffee, Soluble	19	19A ₄₀ ^{35PUY}	1B	.4	30A
Coke, Breeze	25-35	30C _{1/2} ³⁷	3D	1.2	15
Coke, Loose	23-35	30D ₇ ³⁷	3D	1.2	15
Coke, Petrol, Calcined	35-45	40D ₇ ³⁷	3D	1.3	15
Compost	30-50	40D ₇ ^{45TV}	3A-3B	1.0	30A
Concrete, Pre-Mix Dry	85-120	103C _{1/2} ^{36U}	3D	3.0	30B
Copper Ore	120-150	135D _X ³⁶	3D	4.0	30B
Copper Ore, Crushed	100-150	125D ₃ ³⁶	3D	4.0	30B
Copper Sulfate, (Bluestone)	75-95	85C _{1/2} ^{35S}	2A-2B-2C	1.0	30A
Copperas (See Ferrous Sulfate)	—	—	—	—	—
Copra, Cake Ground	40-45	43B ₆ ^{45HW}	1A-1B-1C	.7	30A
Copra, Cake, Lumpy	25-30	28D ₃ ^{35HW}	2A-2B-2C	.8	30A
Copra, Lumpy	22	22E ^{35HW}	2A-2B-2C	1.0	30A
Copra, Meal	40-45	42B ₆ ^{35HW}	2D	.7	30A
Cork, Fine Ground	5-15	10B ₆ ^{35JNY}	1A-1B-1C	.5	30A
Cork, Granulated	12-15	14C _{1/2} ^{35JY}	1A-1B-1C	.5	30A
Corn, Cracked	40-50	45B ₆ ^{25P}	1A-1B-1C	.7	45
Corn Cobs, Ground	17	17C _{1/2} ^{25Y}	1A-1B-1C	.6	45
Corn Cobs, Whole*	12-15	14E ³⁵	2A-2B	2.0	30A
Corn Ear*	56	56E ³⁵	2A-2B	1.7	30A
Corn Germ	21	21B ₆ ^{35PY}	1A-1B-1C	.4	30A
Corn Grits	40-45	43B ₆ ^{35P}	1A-1B-1C	.5	30A
Cornmeal	32-40	36B ₆ ^{35P}	1A-1B	.5	30A
Corn Oil, Cake	25	25D ₇ ^{45HW}	1A-1B	.6	30A
Corn Seed	45	45C _{1/2} ^{25PQ}	1A-1B-1C	.4	45
Corn Shelled	45	45C _{1/2} ²⁵	1A-1B-1C	.4	45

MATERIAL CHARACTERISTICS CHART (cont'd)

Material	Weight lbs. per cu. ft.	Material Code	Component Series	Mat'l. Factor Fm	Conv. Loading %
Corn Sugar	30-35	33B ₆ 35PU	1B	1.0	30A
Cottonseed, Cake, Crushed	40-45	43C _{1/2} 45HW	1A-1B	1.0	30A
Cottonseed, Cake, Lumpy	40-45	43D ₇ 45HW	2A-2B	1.0	30A
Cottonseed, Dry, Delinted	22-40	31C _{1/2} 25X	1A-1B	.9	45
Cottonseed, Dry, Not Delinted	18-25	22C _{1/2} 45XY	1A-1B	.9	30A
Cottonseed, Flakes	20-25	23C _{1/2} 35HWY	1A-1B	.8	30A
Cottonseed, Hulls	12	12B ₆ 35Y	1A-1B	.9	30A
Cottonseed, Meal, Expeller	25-30	28B ₆ 45HW	3A-3B	.5	30A
Cottonseed, Meal, Extracted	35-40	37B ₆ 45HW	1A-1B	.5	30A
Cottonseed, Meats, Dry	40	40B ₆ 35HW	1A-1B	.6	30A
Cottonseed, Meats, Rolled	35-40	38C _{1/2} 45HW	1A-1B	.6	30A
Cracklings, Crushed	40-50	45D ₃ 45HW	2A-2B-2C	1.3	30A
Cryolite, Dust	75-90	83A ₁₀₀ 36L	2D	2.0	30B
Cryolite, Lumpy	90-110	100D ₁₆ 36	2D	2.1	30B
Cullet, Fine	80-120	100C _{1/2} 37	3D	2.0	15
Cullet, Lump	80-120	100D ₁₆ 37	3D	2.5	15
Culm, (See Coal, Anthracite)	—	—	—	—	—
Cupric Sulfate (Copper Sulfate)	—	—	—	—	—
Detergent (See Soap Detergent)	—	—	—	—	—
Diatomaceous Earth	11-17	14A ₄₀ 36Y	3D	1.6	30B
Dicalcium Phosphate	40-50	45A ₄₀ 35	1A-1B-1C	1.6	30A
Disodium Phosphate	25-31	28A ₄₀ 35	3D	.5	30A
Distiller's Grain-Spent Dry	30	30B ₆ 35	2D	.5	30A
Distiller's Grain, Spent Wet	40-60	50C _{1/2} 45V	3A-3B	.8	30A
Dolomite, Crushed	80-100	90C _{1/2} 36	2D	2.0	30B
Dolomite, Lumpy	90-100	95D _X 36	2D	2.0	30B
Earth, Loam, Dry, Loose	76	76C _{1/2} 36	2D	1.2	30B
Ebonite, Crushed	63-70	67C _{1/2} 35	1A-1B-1C	.8	30A
Egg Powder	16	16A ₄₀ 35MPY	1B	1.0	30A
Epsom Salts (Magnesium Sulfate)	40-50	45A ₄₀ 35U	1A-1B-1C	.8	30A
Feldspar, Ground	65-80	73A ₁₀₀ 37	2D	2.0	15
Feldspar, Lumps	90-100	95D ₇ 37	2D	2.0	15
Feldspar, Powder	100	100A ₂₀₀ 36	2D	2.0	30A
Feldspar, Screenings	75-80	78C _{1/2} 37	2D	2.0	15
Ferrous Sulfide—1/2"	120-135	128C _{1/2} 26	1A-1B-1C	2.0	30B
Ferrous Sulfide—100M	105-120	113A ₁₀₀ 36	1A-1B-1C	2.0	30B
Ferrous Sulfate	50-75	63C _{1/2} 35U	2D	1.0	30A
Fish Meal	35-40	38C _{1/2} 45HP	1A-1B-1C	1.0	30A
Fish Scrap	40-50	45D ₇ 45H	2A-2B-2C	1.5	30A
Flaxseed	43-45	44B ₆ 35X	1A-1B-1C	.4	30A
Flaxseed Cake (Linseed Cake)	48-50	49D ₇ 45W	2A-2B	.7	30A
Flaxseed Meal (Linseed Meal)	25-45	33B ₆ 45W	1A-1B	.4	30A
Flour Wheat	33-40	37A ₄₀ 45LP	1B	.6	30A
Flue Dust, Basic Oxygen Furnace	45-60	53A ₄₀ 36LM	3D	3.5	30B
Flue Dust, Blast Furnace	110-125	118A ₄₀ 36	3D	3.5	30B
Flue Dust, Boiler H. Dry	30-45	38A ₄₀ 36LM	3D	3.5	30B
Fluorspar, Fine (Calcium Fluoride)	80-100	90B ₆ 36	2D	2.0	30B
Fluorspar, Lumps	90-110	100D ₇ 36	2D	2.0	30B
Flyash	30-45	38A ₄₀ 36M	3D	3.5	30B
Foundry Sand, Dry (See Sand)	—	—	—	—	—
Fuller's Earth, Dry, Raw	30-40	35A ₄₀ 25	2D	2.0	45
Fuller's Earth, Oily, Spent	60-65	63C _{1/2} 45OW	3D	2.0	30A
Fuller's Earth, Calcined	40	40A ₁₀₀ 25	3D	2.0	45
Galena (See Lead Sulfide)	—	—	—	—	—
Gelatine, Granulated	32	32B ₆ 35PU	1B	.8	30A

MATERIAL CHARACTERISTICS CHART (cont'd)

Material	Weight lbs. per cu. ft.	Material Code	Component Series	Mat'l. Factor Fm	Conv. Loading %
Gilsonite	37	37C _{1/2} 35	3D	1.5	30A
Glass, Batch	80-100	90C _{1/2} 37	3D	2.5	15
Glue, Ground	40	40B ₆ 45U	2D	1.7	30A
Glue, Pearl	40	40C _{1/2} 35U	1A-1B-1C	.5	30A
Glue, Veg. Powdered	40	40A ₄₀ 45U	1A-1B-1C	.6	30A
Gluten, Meal	40	40B ₆ 35P	1B	.6	30A
Granite, Fine	80-90	85C _{1/2} 27	3D	2.5	15
Grape Pomace	15-20	18D ₃ 45U	2D	1.4	30A
Graphite Flake	40	40B ₆ 25LP	1A-1B-1C	.5	45
Graphite Flour	28	28A ₁₀₀ 35LMP	1A-1B-1C	.5	30A
Graphite Ore	65-75	70D _x 35L	2D	1.0	30A
Guano Dry*	70	70C _{1/2} 35	3A-3B	2.0	30A
Gypsum, Calcined	55-60	58B ₆ 35U	2D	1.6	30A
Gypsum, Calcined, Powdered	60-80	70A ₁₀₀ 35U	2D	2.0	30A
Gypsum, Raw -1"	70-80	75D ₃ 25	2D	2.0	30A
Hay, Chopped*	8-12	10C _{1/2} 35JY	2A-2B	1.6	30A
Hexanedioic Acid (See Adipic Acid)	—	—	—	—	—
Hominy, Dry	35-50	43C _{1/2} 25D	1A-1B-1C	.4	45
Hops, Spent, Dry	35	35D ₃ 35	2A-2B-2C	1.0	30A
Hops, Spent, Wet	50-55	53D ₃ 45V	2A-2B	1.5	30A
Ice, Crushed	35-45	40D ₃ 350	2A-2B	.4	30A
Ice, Flaked*	40-45	43C _{1/2} 350	1B	.6	30A
Ice, Cubes	33-35	34D ₃ 350	1B	.4	30A
Ice, Shell	33-35	34D ₃ 450	1B	.4	30A
Ilmenite Ore	140-160	150D ₃ 37	3D	2.0	15
Iron Ore Concentrate	120-180	150A ₄₀ 37	3D	2.2	15
Iron Oxide Pigment	25	25A ₁₀₀ 36LMP	1A-1B-1C	1.0	30B
Iron Oxide, Millscale	75	75C _{1/2} 36	2D	1.6	30B
Iron Pyrites (See Ferrous Sulfate)	—	—	—	—	—
Iron Sulphate (See Ferrous Sulfate)	—	—	—	—	—
Iron Sulfide (See Ferrous Sulfate)	—	—	—	—	—
Iron Vitriol (See Ferrous Sulfate)	—	—	—	—	—
Kafir (Corn)	40-45	43C _{1/2} 25	3D	.5	45
Kaolin Clay	63	63D ₃ 25	2D	2.0	45
Kaolin Clay-Talc	42-56	49A ₄₀ 35LMP	2D	2.0	30A
Kryalith (See Cryolite)	—	—	—	—	—
Lactose	32	32A ₄₀ 35PU	1B	.6	30A
Lamp Black (See Carbon Black)	—	—	—	—	—
Lead Arsenate	72	72A ₄₀ 35R	1A-1B-1C	1.4	30A
Lead Arsenite	72	72A ₄₀ 35R	1A-1B-1C	1.4	30A
Lead Carbonate	240-260	250A ₄₀ 35R	2D	1.0	30A
Lead Ore -1/8"	200-270	235B ₆ 35	3D	1.4	30A
Lead Ore -1/2"	180-230	205C _{1/2} 36	3D	1.4	30B
Lead Oxide (Red Lead)-100 Mesh	30-150	90A ₁₀₀ 35P	2D	1.2	30A
Lead Oxide (Red Lead)-200 Mesh	30-180	105A ₂₀₀ 35LP	2D	1.2	30A
Lead Sulphide -100 Mesh*	240-260	250A ₁₀₀ 35R	2D	—	30A
Lignite (See Coal Lignite)	—	—	—	—	—
Limanite, Ore, Brown	120	120C _{1/2} 47	3D	1.7	15
Lime, Ground, Unslaked	60-65	63B ₆ 35U	1A-1B-1C	.6	30A
Lime, Hydrated	40	40B ₆ 35LM	2D	.8	30A
Lime, Hydrated, Pulverized	32-40	36A ₄₀ 35LM	1A-1B	.6	30A
Lime, Pebble	53-56	55C _{1/2} 25HU	2A-2B	2.0	45
Limestone, Agricultural	68	68B ₆ 35	2D	2.0	30A
Limestone, Crushed	85-90	88D _x 36	2D	2.0	30B
Limestone, Dust	55-95	75A ₄₀ 46MY	2D	1.6-2.0	30B

MATERIAL CHARACTERISTICS CHART (cont'd)

Material	Weight lbs. per cu. ft.	Material Code	Component Series	Mat'l. Factor Fm	Conv. Loading %
Lindane (Benzene Hexachloride)	—	—	—	—	—
Linseed (See Flaxseed)	—	—	—	—	—
Litharge (Lead Oxide)	—	—	—	—	—
Lithopone	45-50	48A ₃₂₅ ^{35MR}	1A-1B	1.0	30A
Maize (See Milo)	—	—	—	—	—
Malt, Dry, Ground	20-30	25B ₆ ^{35NP}	1A-1B-1C	.5	30A
Malt, Meal	36-40	38B ₆ ^{25P}	1A-1B-1C	.4	45
Malt, Dry Whole	20-30	25C _{1/2} ^{35N}	1A-1B-1C	.5	30A
Malt, Sprouts	13-15	14C _{1/2} ^{35P}	1A-1B-1C	.4	30A
Magnesium Chloride (Magnesite)	33	33C _{1/2} ⁴⁵	1A-1B	1.0	30A
Manganese Dioxide*	70-85	78A ₁₀₀ ^{35NRT}	2A-2B	1.5	30A
Manganese Ore	125-140	133D _x ³⁷	3D	2.0	15
Manganese Oxide	120	120A ₁₀₀ ³⁶	2D	2.0	30B
Manganese Sulfate	70	70C _{1/2} ³⁷	3D	2.4	15
Marble, Crushed	80-95	88B ₆ ³⁷	3D	2.0	15
Marl, (Clay)	80	80D _x ³⁶	2D	1.6	30B
Meat, Ground	50-55	53E45HQT _X	2A-2B	1.5	30A
Meat, Scrap (W/bone)	40	40E46H	2D	1.5	30B
Mica, Flakes	17-22	20B ₆ ^{16MY}	2D	1.4	30B
Mica, Ground	13-15	14B ₆ ³⁶	2D	.9	30B
Mica, Pulverized	13-15	14A ₁₀₀ ^{36M}	2D	1.0	30B
Milk, Dried, Flake	5-6	6B ₆ ^{35PUY}	1B	1.0	30A
Milk, Malted	27-30	29A ₄₀ ^{45PX}	1B	.9	30A
Milk, Powdered	20-45	33B ₆ ^{25PM}	1B	.5	45
Milk, Sugar	32	32A ₁₀₀ ^{35PX}	1B	.6	30A
Milk, Whole, Powdered	20-36	28B ₆ ^{35PUX}	1B	.5	30A
Mill Scale (Steel)	120-125	123E46T	3D	3.0	30B
Milo, Ground	32-36	34B ₆ ²⁵	1A-1B-1C	.5	45
Milo, Maize (Kafir)	40-45	43B ₆ ^{15N}	1A-1B-1C	.4	45
Molybdenite Powder	107	107B ₆ ²⁶	2D	1.5	30B
Monosodium Phosphate	50	50B ₆ ³⁶	2D	.6	30B
Mortar, Wet*	150	150E46T	3D	3.0	30B
Mustard Seed	45	45B ₆ ^{15N}	1A-1B-1C	.4	45
Naphthalene Flakes	45	45B ₆ ³⁵	1A-1B-1C	.7	30A
Niacin (Nicotinic Acid)	35	35A ₄₀ ^{35P}	2D	.8	30A
Oats	26	26C _{1/2} ^{25MN}	1A-1B-1C	.4	45
Oats, Crimped	19-26	23C _{1/2} ³⁵	1A-1B-1C	.5	30A
Oats, Crushed	22	22B ₆ ^{45NY}	1B-1B-1C	.6	30A
Oats, Flour	35	35A ₁₀₀ ³⁵	1A-1B-1C	.5	30A
Oat Hulls	8-12	10B ₆ ^{35NY}	1A-1B-1C	.5	30A
Oats, Rolled	19-24	22C _{1/2} ^{35NY}	1A-1B-1C	.6	30A
Oleo Margarine (Margarine)	59	59E45HKPW _X	2A-2B	.4	30A
Orange Peel, Dry	15	15E45	2A-2B	1.5	30A
Oxalic Acid Crystals - Ethane Diacid Crystals	60	60B ₆ ^{35QS}	1A-1B	1.0	30A
Oyster Shells, Ground	50-60	55C _{1/2} ^{36T}	3D	1.6-2.0	30B
Oyster Shells, Whole	80	80D ₃ ^{36TV}	3D	2.1-2.5	30B
Paper Pulp (4% or less)	62	62E45	2A-2B	1.5	30A
Paper Pulp (6% to 15%)	60-62	61E45	2A-2B	1.5	30A
Paraffin Cake —1/2"	45	45C _{1/2} ^{45K}	1A-1B	.6	30A
Peanuts, Clean, in shell	15-20	18D ₃ ^{35Q}	2A-2B	.7	30A
Peanut Meal	30	30B ₆ ^{35P}	1B	.6	30A
Peanuts, Raw, Uncleaned (unshelled)	15-20	18D ₃ ^{36Q}	3D	.7	30B
Peanuts, Shelled	35-45	40C _{1/2} ^{35Q}	1B	.5	30A
Peas, Dried	45-50	48C _{1/2} ^{15NQ}	1A-1B-1C	.5	45
Perlite-Expanded	8-12	10C _{1/2} ³⁶	2D	.6	30B

MATERIAL CHARACTERISTICS CHART (cont'd)

Material	Weight lbs. per cu. ft.	Material Code	Component Series	Mat'l. Factor Fm	Conv. Loading %
Phosphate Acid Fertilizer	60	60B ₆ 25T	2A-2B	1.4	45
Phosphate Disodium (See Sodium Phosphate)	—	—	—	—	—
Phosphate Rock, Broken	75-85	80D _x 36	2D	2.1	30B
Phosphate Rock, Pulverized	60	60B ₆ 36	2D	1.7	30B
Phosphate Sand	90-100	95B ₆ 37	3D	2.0	15
Plaster of Paris (See Gypsum)	—	—	—	—	—
Plumbago (See Graphite)	—	—	—	—	—
Polystyrene Beads	40	40B ₆ 35PQ	1B	.4	30A
Polyvinyl, Chloride Powder	20-30	25A ₁₀₀ 45KT	2B	1.0	30A
Polyvinyl, Chloride Pellets	20-30	25E45KPQT	1B	.6	30A
Polyethelene, Resin Pellets	30-35	33C _{1/2} 45Q	1A-1B	1.0	30A
Potash (Muriate) Dry	70	70B ₆ 37	3D	2.0	15
Potash (Muriate) Mine Run	75	75D _x 37	3D	2.2	15
Potassium Carbonate	51	51B ₆ 36	2D	1.0	30B
Potassium Chloride Pellets	120-130	125C _{1/2} 25TU	3D	1.6	45
Potassium Nitrate -1/2"	76	76C _{1/2} 16NT	3B	1.2	30B
Potassium Nitrate -1/8"	80	80B ₆ 26NT	3B	1.2	30B
Potassium Sulfate	42-48	45B ₆ 46X	2D	1.0	30B
Potato Flour	48	48A ₂₀₀ 35MNP	1A-1B	.5	30A
Pumice -1/8"	42-48	45B ₆ 46	3D	1.6	30B
Pyrite, Pellets	120-130	125C _{1/2} 26	3D	2.0	30A
Quartz, -100Mesh	70-80	75A ₁₀₀ 27	3D	1.7	15
Quartz, -1/2"	80-90	85C _{1/2} 27	3D	2.0	15
Rice, Bran	20	20B ₆ 35NY	1A-1B-1C	.4	30A
Rice, Grits	42-45	44B ₆ 35P	1A-1B-1C	.4	30A
Rice, Polished	30	30C _{1/2} 15P	1A-1B-1C	.4	45
Rice, Hulled	45-49	47C _{1/2} 25P	1A-1B-1C	.4	45
Rice, Hulls	20-21	21B ₆ 35NY	1A-1B-1C	.4	30A
Rice, Rough	32-36	34C _{1/2} 35N	1A-1B-1C	.6	30A
Rosin -1/2"	65-68	67C _{1/2} 45Q	1A-1B-1C	1.5	30A
Rubber, Reclaimed Ground	23-50	37C _{1/2} 45	1A-1B-1C	1.5	30A
Rubber, Pelleted	50-55	53D ₃ 45	2A- 2B-2C	2.5	30A
Rye	42-48	45B ₆ 15N	1A-1B-1C	.4	45
Rye Bran	15-20	18B ₆ 35Y	1A-1B-1C	.4	30A
Rye Feed	33	33B ₆ 35N	1A-1B-1C	.5	30A
Rye Meal	35-40	38B ₆ 35	1A-1B-1C	.5	30A
Rye Middlings	42	42B ₆ 35	1A-1B	.5	30A
Rye, Shorts	32-33	33C _{1/2} 35	2A-2B	.5	30A
Safflower, Cake	50	50D ₃ 26	2D	.6	30B
Safflower, Meal	50	50B ₆ 35	1A-1B-1C	.6	30A
Safflower Seed	45	45B ₆ 15N	1A-1B-1C	.4	45
Saffron (See Safflower)	—	—	—	—	—
Sal Ammoniac (Ammonium Chloride)	—	—	—	—	—
Salt Cake, Dry Coarse	85	85B ₆ 36TU	3D	2.1	30B
Salt Cake, Dry Pulverized	65-85	75B ₆ 36TU	3D	1.7	30B
Salicylic Acid	29	29B ₆ 37U	3D	.6	15
Salt, Dry Coarse	45-60	53C _{1/2} 36TU	3D	1.2	30B
Salt, Dry Fine	70-80	75B ₆ 36TU	3D	1.7	30B
Saltpeter - (See Potassium Nitrate)	—	—	—	—	—
Sand Dry Bank (Damp)	110-130	120B ₆ 47	3D	2.8	15
Sand Dry Bank (Dry)	90-110	100B ₆ 37	3D	1.7	15
Sand Dry Silica	90-100	95B ₆ 27	3D	2.0	15
Sand Foundry (Shake Out)	90-100	95D ₃ 37Z	3D	2.6	15
Sand (Resin Coated) Silica	104	104B ₆ 27	3D	2.0	15

MATERIAL CHARACTERISTICS CHART (cont'd)

Material	Weight lbs. per cu. ft.	Material Code	Component Series	Mat'l. Factor Fm	Conv. Loading %
Sand (Resin Coated Zircon)	115	115A ₁₀₀ 27	3D	2.3	15
Sawdust, Dry	10-13	12B ₆ 45UX	1A-1B-1C	.7	30A
Sea-Coal	65	65B ₆ 36	2D	1.0	30B
Sesame Seed	27-41	34B ₆ 26	2D	.6	30B
Shale, Crushed	85-90	88C _{1/2} 36	2D	2.0	30B
Shellac, Powdered or Granulated	31	31B ₆ 35P	1B	.6	30A
Silicon Dioxide (See Quartz)	—	—	—	—	—
Silica, Flour	80	80A ₄₀ 46	2D	1.5	30B
Silica Gel + 1/2"-3"	45	45D ₃ 37HKQU	3D	2.0	15
Slag, Blast Furnace Crushed	130-180	155D ₃ 37Y	3D	2.4	15
Slag, Furnace Granular, Dry	60-65	63C _{1/2} 37	3D	2.2	15
Slate, Crushed, -1/2"	80-90	85C _{1/2} 36	2D	2.0	30B
Slate, Ground, -1/8"	82-85	84B ₆ 36	2D	2.0	30B
Sludge, Sewage, Dried	40-50	45E47TW	3D	.8	15
Sludge, Sewage, Dry Ground	45-55	50B46S	2D	.8	30B
Soap, Beads or Granules	15-35	25B ₆ 35Q	1B-1B-1C	.6	30A
Soap, Chips	15-25	20C _{1/2} 35Q	1A-1B-1C	.6	30A
Soap Detergent	15-50	33B ₆ 35FQ	1A-1B-1C	.8	30A
Soap, Flakes	5-15	10B ₆ 35QXY	1A-1B-1C	.6	30A
Soap, Powder	20-25	23B ₆ 25X	1A-1B-1C	.9	45
Soapstone, Talc, Fine	40-50	45A ₂₀₀ 45XY	1A-1B-1C	2.0	30A
Soda Ash, Heavy	55-65	60B ₆ 36	2D	1.0	30B
Soda Ash, Light	20-35	28A ₄₀ 36Y	2D	.8	30B
Sodium Aluminate, Ground	72	72B ₆ 36	2D	1.0	30B
Sodium Aluminum Fluoride (See Kryolite)	—	—	—	—	—
Sodium Aluminum Sulfate*	75	75A ₁₀₀ 36	2D	1.0	30B
Sodium Bentonite (See Bentonite)	—	—	—	—	—
Sodium Bicarbonate (See Baking Soda)	—	—	—	—	—
Sodium Chloride (See Salt)	—	—	—	—	—
Sodium Carbonate (See Soda Ash)	—	—	—	—	—
Sodium Hydrate (See Caustic Soda)	—	—	—	—	—
Sodium Hydroxide (See Caustic Soda)	—	—	—	—	—
Sodium Borate (See Borax)	—	—	—	—	—
Sodium Nitrate	70-80	75D ₃ 25NS	2A-2B	1.2	45
Sodium Phosphate	50-60	55A35	1A-1B	.9	30A
Sodium Sulfate (See Salt Cake)	—	—	—	—	—
Sodium Sulfite	96	96B ₆ 46X	2D	1.5	30B
Sorghum, Seed (See Kafir or Milo)	—	—	—	—	—
Soybean, Cake	40-43	42D ₃ 35W	2A-1B-1C	1.0	30A
Soybean, Cracked	30-40	35C _{1/2} 36NW	2B	.5	30B
Soybean, Flake, Raw	18-25	22C _{1/2} 35Y	1A-1B-1C	.8	30A
Soybean, Flour	27-30	29A ₄₀ 35MN	1A-1B-1C	.8	30A
Soybean Meal, Cold	40	40B ₆ 35	1A-1B-1C	.6	30A
Soybean Meal Hot	40-40	40B ₆ 35T	2A-2B	.5	30A
Soybeans, Whole	45-50	48C _{1/2} 26NW	—	1.0	30B
Starch	25-50	38A ₄₀ 15M	1A-1B-1C	1.0	45
Steel Turnings, Crushed	100-150	125D ₃ 46WV	3D	3.5	30B
Sugar Beet, Pulp, Dry	12-15	14C _{1/2} 26	2D	.9	30B
Sugar Beet, Pulp, Wet	25-45	35C _{1/2} 35X	1A-1B-1C	1.2	30A
Sugar, Refined, Granulated Dry	50-55	53B ₆ 35PU	1B	2.0	30A
Sugar, Refined, Granulated Wet	55-65	60C _{1/2} 35X	1B	2.0	30A
Sugar, Powdered	50-60	55A ₁₀₀ 35PX	1B	.8	30A
Sugar, Raw	55-65	60B ₆ 35PX	1B	1.5	30A
Sulphur, Crushed -1/2"	50-60	55C _{1/2} 35N	1A-1B	.8	30A
Sulphur, Lumpy, -3"	80-85	83D ₃ 35N	2A-2B	.8	30A

MATERIAL CHARACTERISTICS CHART (cont'd)

Material	Weight lbs. per cu. ft.	Material Code	Component Series	Mat'l. Factor Fm	Conv. Loading %
Sulphur, Powdered	50-60	55A ₄₀ ^{35MN}	1A-1B	.7	30A
Sunflower Seed	19-38	29C _{1/2} ¹⁵	1A-1B-1C	.5	45
Talcum,—1/2"	80-90	85C _{1/2} ³⁶	2D	.9	30B
Talcum Powder	50-60	55A ₂₀₀ ^{36M}	2D	.8	30B
Tanbark, Ground*	55	55B ₆ ⁴⁵	1A-1B-1C	.7	30A
Timothy Seed	36	36B ₆ ^{35NY}	1A-1B-1C	.6	30A
Titanium Dioxide (See Ilmenite Ore)	—	—	—	—	—
Tobacco, Scraps	15-25	20D ₃ ^{45Y}	2A-2B	.8	30A
Tobacco, Snuff	30	30B ₆ ^{45MQ}	1A-1B-1C	.9	30A
Tricalcium Phosphate	40-50	45A ₄₀ ⁴⁵	1A-1B	1.6	30A
Triple Super Phosphate	50-55	53B ₆ ^{36RS}	3D	2.0	30B
Trisodium Phosphate	60	60C _{1/2} ³⁶	2D	1.7	30B
Trisodium Phosphate Granular	60	60B ₆ ³⁶	2D	1.7	30B
Trisodium Phosphate, Pulverized	50	50A ₄₀ ³⁶	2D	1.6	30B
Tung Nut Meats, Crushed	28	28D ₃ ^{25W}	2A-2B	.8	45
Tung Nuts	25-30	28D ₃ ¹⁵	2A-2B	.7	45
Urea Prills, Coated	43-46	45B ₆ ²⁵	1A-1B-1C	1.2	30A
Vermiculite, Expanded	16	16C _{1/2} ^{35Y}	1A-1B	.5	30B
Vermiculite, Ore	80	80D ₃ ³⁶	2D	1.0	30B
Vetch	48	48B ₆ ^{16N}	1A-1B-1C	.4	30B
Walnut Shells, Crushed	35-45	40B ₆ ³⁶	2D	1.0	30B
Wheat	45-48	47C _{1/2} ^{25N}	1A-1B-1C	.4	45
Wheat, Cracked	40-45	43B ₆ ^{25N}	1A-1B-1C	.4	45
Wheat, Germ	18-28	23B ₆ ²⁵	1A-1B-1C	.4	45
White Lead, Dry	75-100	88A ₄₀ ^{36MR}	2D	1.0	30B
Wood Chips, Screened	10-30	20D ₃ ^{45VY}	2A-2B	.6	30A
Wood Flour	16-36	26B ₆ ^{35N}	1A-1B	.6	30A
Wood Shavings	8-16	12E ₄₅ ^{VY}	2A-2B	1.5	30A
Zinc, Concentrate Residue	75-80	78B ₆ ³⁷	3D	1.0	15
Zinc Oxide, Heavy	30-35	33A ₁₀₀ ^{45X}	1A-1B	1.0	30A
Zinc Oxide, Light	10-15	13A ₁₀₀ ^{45XY}	1A-1B	1.0	30A

*Consult our engineering department.

MATERIAL CLASSIFICATION CODE CHART



Major Class	Material Characteristics Included	Code Designation
Density	Bulk Density, Loose	Average Lbs/CF
Size	Very Fine No. 200 Sieve (.0029") And Under No. 100 Sieve (.0059") And Under No. 40 Sieve (.016") And Under	A ₂₀₀ A ₁₀₀ A ₄₀
	Fine No. 6 Sieve (.132") And Under	B ₆
	Granular 1/2" And Under 3" And Under 7" And Under	C _{1/2} D ₃ D ₇
	Lumpy 16" And Under Over 16" To Be Specified X=Actual Maximum Size	D ₁₆ D _X
	Irregular Stringy, Fibrous, Cylindrical, Slabs, Etc.	E
Flowability	Very Free Flowing - Flow Function >10	1
	Free Flowing - Flow Function >4 But < 10	2
	Average Flowability - Flow Function >2 But < 4	3
	Sluggish - Flow Function < 2	4
Abrasiveness	Mildly Abrasive	5
	Moderately Abrasive	6
	Extremely Abrasive	7
Miscellaneous Properties Or Hazards	Builds Up and Hardens	F
	Generates Static Electricity	G
	Decomposes - Deteriorates in Storage	H
	Flammability	J
	Becomes Plastic or Tends to Soften	K
	Very Dusty	L
	Aerates and Becomes Fluid	M
	Explosiveness	N
	Stickiness-Adhesion	O
	Contaminable, Affecting Use	P
	Degradable, Affecting Use	Q
	Gives Off Harmful or Toxic Gas or Fumes	R
	Highly Corrosive	S
	Mildly Corrosive	T
	Hygroscopic	U
	Interlocks, Mats or Agglomerates	V
	Oils Present	W
Packs Under Pressure	X	
Very Light and Fluffy - May Be Windswept	Y	
Elevated Temperature	Z	

COMPONENT GROUP SELECTION GUIDE CHART

Material Classification Code			Group Number Designation	Component Group Letter Designation				
Material Size Classification	Abrasive Number	Corrosiveness Letter		Type of Intermediate Hanger Bearing				
				Babbitted or Bronze	Self Lubricating	Ball Δ Bearing	Hard + Iron	
A ₂₀₀ A ₁₀₀ A ₄₀	B ₆	5	Non-Corr.	1	A	B	C	—
	C _{1/2}		T	2	A	B	—	—
			S	3	A	B	—	—
D ₃ D ₇ or E D ₁₆ D _x	5	Non-Corr.	2	A	B	C	—	
		T	2	A	B	—	—	
		S	3	A	B	—	—	
A ₂₀₀ A ₁₀₀ A ₄₀	B ₆	6	Non-Corr.	2	—	—	—	D
	C _{1/2}		T	3	—	—	—	D
			S	3*	—	—	—	D
D ₃ D ₇ or E D ₁₆ D _x	6	Non-Corr.	2	—	—	—	D	
		T	3	—	—	—	D	
		S	3*	—	—	—	D	
A ₂₀₀ A ₁₀₀ A ₄₀	B ₆	7	Non-Corr.	3	—	—	—	D
	C _{1/2}		T	3	—	—	—	D
			S	3*	—	—	—	D
D ₃ D ₇ or E D ₁₆ D _x	7	Non-Corr.	3	—	—	—	D	
		T	3	—	—	—	D	
		S	3*	—	—	—	D	

* For very corrosive conditions (codes 6S or 7S) lighter gauge special anti-corrosion materials may be used.

Δ Ball bearings are not usually recommended for conveyors handling materials partly or wholly finely ground. (Code A)

+Any abrasive material which is flammable, or which may contain explosive dust, consult our engineering department for bearing recommendations.

CONVEYOR CAPACITY



Required Information

Type and condition of material being conveyed.

Conveyor capacity in cubic feet per hour.

Maximum particle size in inches.

1. LOADING

Refer to Material Tables, pages 2-10 and find the recommended conveyor loading per cent for the material to be conveyed.

2. CAPACITY

In Capacity Table, page 14, find the group that corresponds to the recommended per-cent loading. Refer to the capacity at maximum R.P.M. column in this group, and find the capacity which equals, or just exceeds, that required; note the conveyor size and maximum lump size corresponding to this value.

3. PARTICLE SIZE

If this size does not exceed the maximum particle size being conveyed, the selected conveyor size will be adequate. If this tabular value is less than the maximum particle size being conveyed, select a larger conveyor whose tabular maximum lump size equals, or exceeds, the particle size being conveyed.

4. SPEED

Conveyor speed (S_c) may be found from the following equation:

$$S_c = \frac{C_v}{C_{vi}}$$

C_v = Conveyor capacity in cubic feet per hour.

C_{vi} = Conveyor capacity in cubic feet per hour at one rpm.

100% LOADING

Capacity charts and tables given for 100% loaded conveyors are average values for pulverulent materials, and it is recommended that our engineering department be consulted concerning particular materials.

PITCH

Capacity and speed tables are based on standard pitch conveyors, (pitch equals conveyor diameter). For other than standard pitch, determine the required conveyor speed (S_c), as outlined above, and multiply by the conveyor pitch factor (F_p) from the following table.

$$S_c = F_p (S_c \text{ std. pitch})$$

Pitch		F_p
Standard	(pitch equals diameter)	1.00
Half	(pitch equals 1/2 diameter)	2.00
Short	(pitch equals 2/3 diameter)	1.50
Long	(pitch equals 1-1/2 diameters)	0.67

FLIGHTS

When using equally spaced multiple flights, i.e. more than one helicoid interlaced, the pitch of a single helicoid only need be considered for capacity determinations.

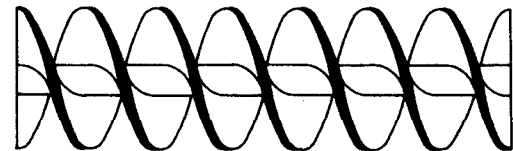

For example, if a double flight - short pitch conveyor is under consideration, the pitch factor (F_p) for speed calculations would be 2/3 diameter ($F_p = 1.50$) rather than 1/3 diameter.

CAPACITY

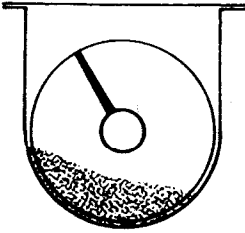
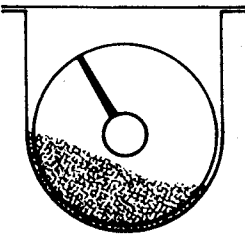
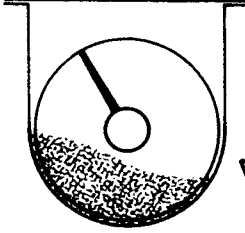
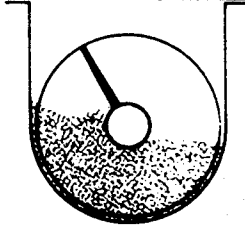
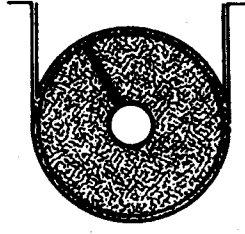

CONVEYOR LOADING %	Screw Diameter	Maximum Lump Size	Capacity Cubic Feet Per Hour		Maximum Economical Speed RPM
			At One RPM	At Maximum RPM	
 15%	4	5/8	0.21	15	72
	6	3/4	0.75	51	68
	9	1-1/2	2.8	179	64
	10	1-3/4	3.7	229	62
	12	2	6.7	389	58
	14	2-1/2	10.8	594	55
	16	3	15.9	843	53
	18	3	22.7	1,135	50
	20	3-1/2	31.2	1,404	45
24	4	58.0	2,030	35	
 30% A	4	5/8	0.41	53	130
	6	3/4	1.5	183	122
	9	1-1/2	5.6	644	115
	10	1-3/4	7.2	814	113
	12	2	13.3	1,370	103
	14	2-1/2	21.1	2,004	95
	16	3	31.5	2,803	89
	18	3	45.7	3,839	84
	20	3-1/2	62.4	4,867	78
24	4	118.0	7,788	66	
 30% B ABRASIVE PRODUCTS	4	5/8	0.41	29	72
	6	3/4	1.5	102	68
	9	1-1/2	5.6	358	64
	10	1-3/4	7.2	446	62
	12	2	13.3	771	58
	14	2-1/2	21.1	1,160	55
	16	3	31.5	1,670	53
	18	3	45.7	2,285	50
	20	3-1/2	62.4	2,745	44
24	4	118.0	4,050	34	
 45%	4	5/8	0.62	114	184
	6	3/4	2.28	406	178
	9	1-1/2	8.0	1,296	162
	10	1-3/4	10.9	1,700	156
	12	2	19.5	2,808	144
	14	2-1/2	31.0	4,278	138
	16	3	46.6	5,918	127
	18	3	66.3	8,022	121
	20	3-1/2	95.6	10,611	111
24	4	172.0	15,480	90	
 100%	4	5/8	1.3	407	
	6	3/4	4.8	1,425	
	9	1-1/2	17.0	4,590	
	10	1-3/4	24.0	6,336	
	12	2	44.0	11,088	
	14	2-1/2	68.0	15,912	
	16	3	104.0	22,464	
	18	3	150.0	31,050	
	20	3-1/2	208.0	39,312	
24	4	340.0	52,020		

HORSEPOWER



The following procedures for the determination of conveyor horsepower are based on the assumption that conveyors are installed with correct alignment of components and that speeds and capacities are based on those set forth in the preceding capacity equations and tables.

Required Information

Conveyor size	Conveyor speed
Conveyor capacity	Material conveyed
Conveyor length	Hanger bearing type

Calculated Solution

For more complex installations, the following four independent calculations are to be preferred.

- ① Conveyor friction horsepower HP_f
- ② Conveyed material horsepower HP_m
- ③ Conveyor total horsepower HP_t
- ④ Drive horsepower HP_d

① HP_f Conveyor Friction Horsepower

The horsepower required to overcome friction in the moving parts of the conveyor assembly may be determined by the following equation:

$$HP_f = \frac{L_c S_c F_c F_b}{1,000,000}$$

L_c = Total length, in feet, of conveyor under consideration.

S_c = Speed of conveyor in rpm, maximum in the case of variable speed drives.

F_c = Conveyor diameter factor from the table on page 16.

F_b = Hanger bearing type factor from the table on page 16.

② HP_m Conveyed Material Horsepower

Horsepower required to convey material horizontally is determined from the following equation:

$$HP_m = \frac{C_v M L_c F_m}{1,000,000}$$

or

$$= \frac{C_w L_c F_m}{1,000,000}$$

C_v = Conveyor capacity in cubic feet per hour.

M = Average material weight in pounds per cubic foot.

L_c = Total conveyor length in feet.

F_m = Material horsepower factor from tables, pages 2-10.

C_w = Conveyor capacity in pounds per hour.

③ HP_t Conveyor Total Horsepower*

Total horsepower required at the conveyor drive shaft may be determined from the following:

$$HP_t = \frac{(HP_f + HP_m) F_o}{.85 \text{ DRIVE EFFICIENCY}}$$

HP_f = Conveyor friction horsepower

HP_m = Horsepower required to convey material.

F_o = Conveyor overload factor from the chart on page 16.

*NOTE ...

SCREW CONVEYORS OR FEEDERS LOCATED UNDER HOPPERS OR BINS MAY REQUIRE ADDITIONAL HORSEPOWER TO HANDLE THE HEADLOAD. FOR THESE APPLICATIONS CONSULT C.I.

④ HP_d Drive Horsepower

The overload factor F_o is a correction for calculated horsepowers of less than five horsepower. This factor is necessary because screw conveyors often require a greater torque range than small motors are able to provide. In other words, small overloads or minor choke conditions could easily stall a drive and create an intolerable nuisance in a continuous process. Increasing the horsepower of these small motors has been found a satisfactory means of correcting such undesirable conditions, and the factor F_o does just that.

HORSEPOWER FACTORS

F_c Conveyor Diameter Factor

Diameter	Factor	Diameter	Factor
4	12	14	78
6	18	16	107
9	31	18	139
10	38	20	165
12	55	24	226

F_b Conveyor Hanger Bearing Factor

Bearing Type	Factor	Bearing Type	Factor
Arguto	1.7*	Manganese Steel	4.4*
Babbitt	1.6	Nylon	2.0*
Ball	1.0	Oilite	1.7*
Bronze	1.7	Stellite	4.3*
(self lubricating)	1.7*	Teflon	2.0*
Graphite Bronze	1.7*	Hard Iron	4.4*
Graphitex	2.0*	Wood	1.8
Lignum Vitae	1.7*	Nylon	1.7

* Non lubricated bearings.

CONVEYORS WITH MODIFIED FLIGHTS

The procedure for calculation of horsepower for conveyors with special or modified flights is identical to that used for standard conveyors except that the Material Horsepower must be multiplied by one or more of the following applicable factors:

MODIFIED FLIGHT FACTORS

Flight Type	Conveyor Loading			
	15	30	45	95
Cut Flight	1.10	1.15	1.20	1.3
Cut & Folded	1.3	1.5	1.7	2.2
Ribbon Flight	1.05	1.14	1.20	

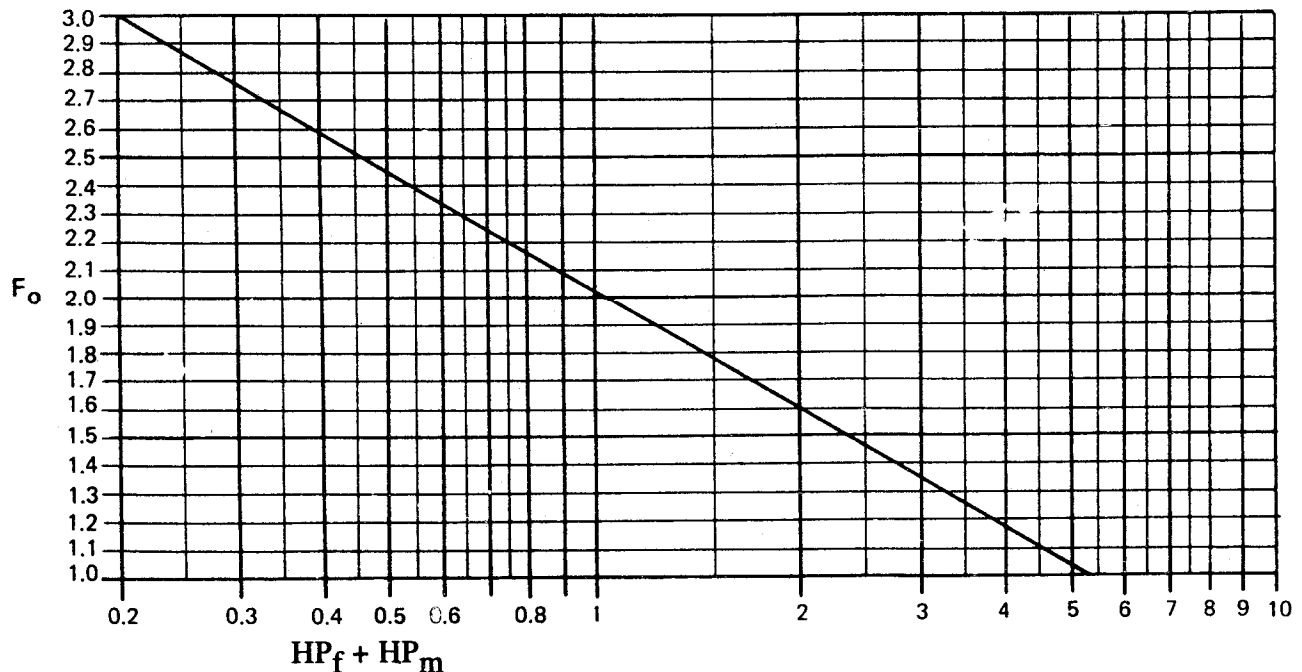

Trace the value of $HP_f + HP_m$ vertically to the diagonal line, then across to the left where F_o value is listed.

CONVEYORS WITH PADDLES*

Factor *	Paddles Per Pitch			
	1	2	3	4
	1.29	1.58	1.87	2.16

*Std. paddles at 45 reverse pitch

Total Shaft Horsepower (TSHP) is calculated by adding Material Horsepower, multiplied by the appropriate modified flight factor or factors to Friction Horsepower.

NOTE

Conveyors which have deviation in pitch only do not require special consideration, and their horsepower calculations are as described for standard conveyors.

INCLINED CONVEYORS.

Screw Conveyors can be operated with the path inclined upward, but the capacity decreases rapidly as the inclination increases. A standard pitch screw inclined at 15 degrees, with the horizontal has 70 per cent of its horizontal capacity; if it is inclined 25 degrees, the capacity is reduced to 40 per cent; if it is inclined 45 degrees, the material will move along the floor of the trough but at a greatly reduced rate. For steep inclines the helix may have a short pitch, and the trough may be made tubular; then the capacity loss is less. Thus, with a jam feed and 45 degrees incline such a conveyor has a capacity about 50 per cent of its capacity when horizontal.

The bearing hangers of inclined conveyors should be of T design to reduce the interference with the flow of the material. It may be desirable to use a few turns of double helix each side of the bearing hangers. With suitable forced feed a screw conveyor in a vertical position will lift material if the rotating speed is high and there are no intermediate bearings. Such a conveyor is not self-cleaning and should not be used for material which will sour or spoil.

COMPONENT GROUPS CHARTS



Normal Service **Component Groups 1A, 1B and 1C**
Regular screw flights and troughs

Screw Dia. Inches	Coupling Dia. Inches	Screw Number		Thickness, U.S. Std. Gauge or Inches	
		Helicoid Flights	Sectional Flights	Trough	Cover
6	1-1/2	6H304	6S309	14 ga.	14 ga.
9	1-1/2	9H306	9S309	14 ga.	14 ga.
9	2	9H406	9S409	14 ga.	14 ga.
12	2	12H408	12S409	12 ga.	14 ga.
12	2-7/16	12H508	12S509	12 ga.	14 ga.
14	2-7/16	14H508	14S509	12 ga.	14 ga.
16	3	16H610	16S612	12 ga.	14 ga.
18	3	—	18S612	10 ga.	12 ga.
20	3	—	20S612	10 ga.	12 ga.
24	3-7/16	—	24S712	10 ga.	12 ga.

Heavy Service **Component Groups 2A, 2B, 2C and 2D**
Heavy flights and heavy trough

Screw Dia. Inches	Coupling Dia. Inches	Screw Number		Thickness, U.S. Std. Gauge or Inches	
		Helicoid Flights	Sectional Flights	Trough	Cover
6	1-1/2	6H308	6S309	12 ga.	14 ga.
9	1-1/2	9H312	9S309	10 ga.	14 ga.
9	2	9H412	9S412	10 ga.	14 ga.
12	2	12H412	12S412	3/16 in.	14 ga.
12	2-7/16	12H512	12S512	3/16 in.	14 ga.
12	3	12H614	12S616	3/16 in.	14 ga.
14	2-7/16	—	14S512	3/16 in.	14 ga.
14	3	14H614	14S616	3/16 in.	14 ga.
16	3	16H614	16S616	3/16 in.	14 ga.
18	3	—	18S616	3/16 in.	12 ga.
20	3	—	20S616	3/16 in.	12 ga.
24	3-7/16	—	24S716	3/16 in.	12 ga.

Extra Heavy Service **Component Groups 3A, 3B and 3D**
Extra heavy flights and extra heavy trough

Screw Dia. Inches	Coupling Dia. Inches	Screw Number		Thickness, U.S. Std. Gauge or Inches	
		Helicoid Flights	Sectional Flights	Trough	Cover
6	1-1/2	6H312	6S312	10 ga.	14 ga.
9	1-1/2	9H312	9S312	3/16 in.	14 ga.
9	2	9H414	9S416	3/16 in.	14 ga.
12	2	12H412	12S412	1/4 in.	14 ga.
12	2-7/16	12H512	12S512	1/4 in.	14 ga.
12	3	12H614	12S616	1/4 in.	14 ga.
14	3	—	14S624	1/4 in.	14 ga.
16	3	—	16S624	1/4 in.	14 ga.
18	3	—	18S624	1/4 in.	12 ga.
20	3	—	20S624	1/4 in.	12 ga.
24	3-7/16	—	24S724	1/4 in.	12 ga.

COMPARISON TABLE



HELICOID SIZE DESIGNATION

The letter "H" indicates screw conveyor with helicoid flighting. The figures to the left of the letters indicate the nominal outside diameter of the conveyor in inches. The first figure following the letters is twice the diameter of the couplings in inches. The last two figures indicate the nominal thickness of flighting at the outer edge in 1/64". Thus conveyor 12H408 indicates 12" diameter helicoid conveyor for 2" couplings with flighting 8/64" or 1/8" thickness at outer edge.



BUTTWELD SIZE DESIGNATION

The letter "S" indicates screw conveyor with buttweld flights. The figures to the left of the letters indicate the nominal outside diameter of the conveyor in inches. The first figure following the letters is twice the diameter of the coupling in inches. The last two figures indicate the nominal thickness of flight in 1/64". Thus conveyor 12S612 indicates 12" diameter sectional flight conveyor for 3" couplings with flights 12/64" or 3/16" nominal thickness.

COMPARISON TABLES OF HELICOID & SECTIONAL FLIGHT CONVEYOR SCREWS

HELICOID FLIGHT							SECTIONAL FLIGHT EQUIVALENT			
Screw Dia. Inches	Conveyor Screw Size Designation	Former Designation	Coupling Diameter Inches	Nominal Inside Dia of Pipe Inches	Thickness of Flight - Inches		Conveyor Screw Size Designation	Coupling Diameter Inches	Nominal Inside Dia of Pipe Inches	Thickness of Flight
					Inner Edge	Outer Edge				
4	4H 204	4 Standard	1	1-1/4	1/8	1/16	4S 209	1	1-1/4	10 ga.
	4H 206	4 X	1	1-1/4	3/16	3/32				
6	6H 304	6 Standard	1-1/2	2	1/8	1/16	6S 309	1-1/2	2	10 ga.
	6H 308	6 X	1-1/2	2	1/4	1/8				
	6H 312	6 XX	1-1/2	2	3/8	3/16				
9	9H 306	9 Standard	1-1/2	2	3/16	3/32	9S 309	1-1/2	2	10 ga.
	9H 406	9 Special	2	2-1/2	3/16	3/32				
	9H 312	9 X	1-1/2	2	3/8	3/16				
	9H 412	9 XX	2	2-1/2	3/8	3/16				
	9H 414	9 XXX	2	2-1/2	7/16	7/32				
10	10H 306	10 Standard	1-1/2	2	3/16	3/32	10S 309	1-1/2	2	10 ga.
	10H 412	10 XX	2	2-1/2	3/8	3/16				
12	12H 408	12 Standard	2	2-1/2	1/4	1/8	12S 412	2	2-1/2	3/16"
	12H 508	12 Special	2-7/16	3	1/4	1/8				
	12H 412	12 X	2	2-1/2	3/8	3/16				
	12H 512	12 XX	2-7/16	3	3/8	3/16				
	12H 614	12 XXX	3	3-1/2	7/16	7/32				
14	14H 508	14 Standard	2-7/16	3	1/4	1/8	14S 512	2-7/16	3	3/16"
	14H 614	14 XX	3	3-1/2	7/16	7/32				
16	16H 610	16 Standard	3	3-1/2	5/16	5/32	16S 612	3	3-1/2	3/16"
	16H 614	16 XX	3	4	7/16	7/32				

CONVEYOR SCREWS



Single Flight Standard Pitch

conveyor screws are considered to be standard and are used for the general conveying of most materials.

LEFT HAND

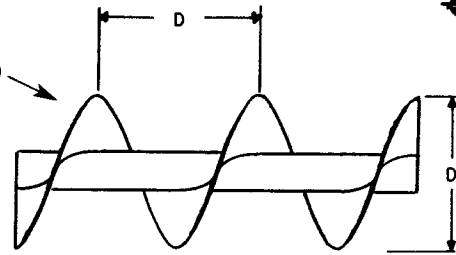

Single Flight Short Pitch

conveyor screws are frequently employed as feeders and are recommended for inclined conveyors in excess of 20 degrees.

RIGHT HAND

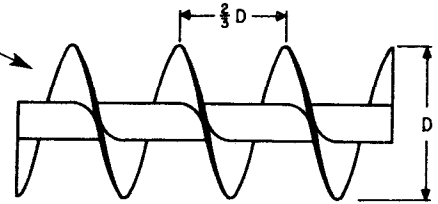

Double Flight Standard Pitch

conveyor screws are frequently required for smooth conveying and discharge of certain materials.

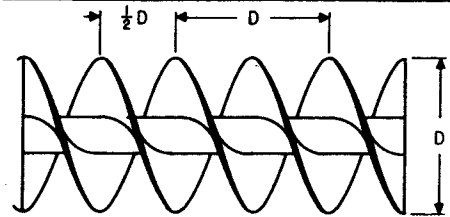

Double Flight Short Pitch

conveyor screws provide an even and regulated flow of materials with fluid characteristics.

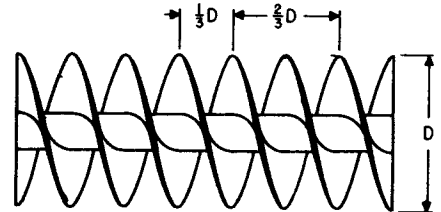

Single Flight Long Pitch

conveyor screws provide a means for the agitation of liquids or the rapid conveying of very free flowing materials.

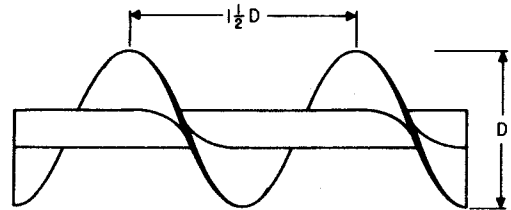

Single Flight Standard Pitch Tapered

conveyor screws are employed for feeding lumpy material from storage. Withdrawal is uniform over full length of feed opening.

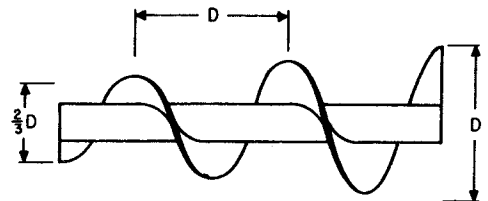

Double Flight Standard Pitch Tapered

conveyor screws are used for feeding free flowing materials from storage with uniform withdrawal for full length of feed opening.

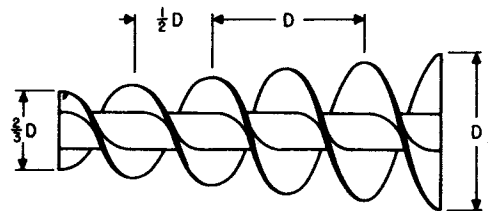

Multiple Ribbon Flight Conveyor Screws

This type of screw consists of two or more ribbon flights of different diameters and opposite hand, mounted one within the other on the same pipe or shaft by rigid supporting lugs. Material is moved forward by one flight and backward by the other, thereby inducing positive and thorough mixing.

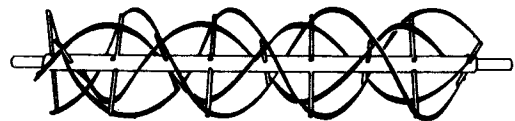

CONVEYOR SCREWS



Single Flight Variable Pitch

conveyor screws are required for feeding some very free flowing materials with uniform withdrawal over full length of feed opening.

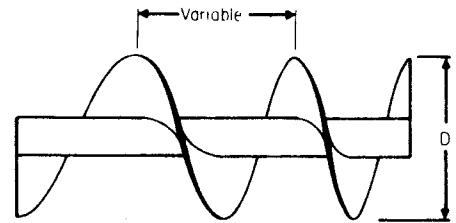

Single Flight Standard Pitch Ribbon

conveyor screws are required for viscous, gummy or sticky materials which tend to adhere to flighting and pipe.

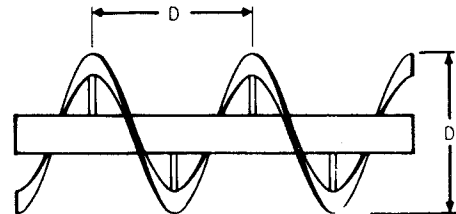

Single Flight Standard Pitch - Paddle

conveyor screws are fitted with adjustable paddles which oppose the flow of material sufficiently to provide moderate mixing in transit.

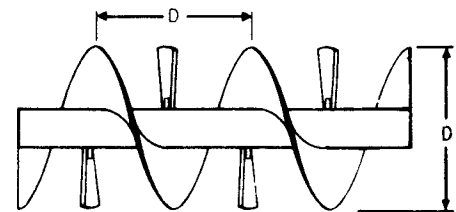

Single Flight Standard Pitch - Cut Flight

conveyor screws are produced with notches at the outer helicoid edges, providing moderate agitation of material in transit.

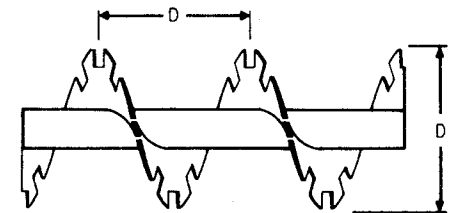

Single Flight Standard Pitch - Cut and Folded

conveyor screws are provided with folded segments at the outer edge which tend to lift and spill the material in transit for aeration and mixing.

Direction of Material Flow →

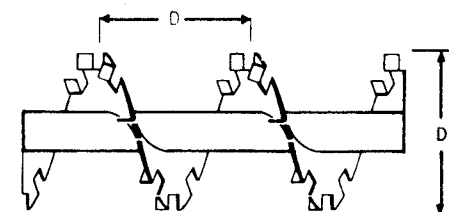

Cut Flight and Paddle

conveyor screws provide a means for a high degree of mixing and aeration of material in transit.

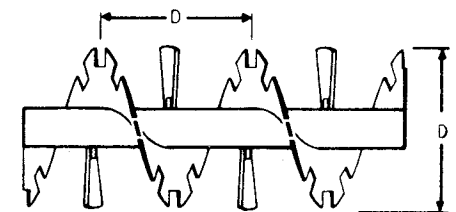

Paddle

conveyor screws permit the control of conveying and mixing action by the angular adjustment of formed steel paddles.

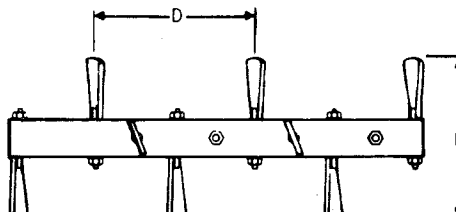

SPECIAL SCREW APPLICATIONS



Abrasion-Resistance Screw Conveyors

In conveying applications where extreme abrasion is a problem, hard-surfaced, Abrasion-Resistance conveyor screws afford an effective, practical and economical solution. Hard-surfaced screws have been utilized successfully in numerous types of applications and may be expected to increase normal service life over standard mild steel conveyors by as much as from 500 to 800%. In certain applications an even greater degree of wear life may be obtained. To produce its hard-surfaced conveyors, a special alloy is applied to the carrying area of the flight face. For most typical applications, the alloy may be applied in the standard width (see table). For extreme applications, full-face application is recommended. The conveyor pipe may also be hard-surfaced.

Hardness

The alloy applied to a mild steel conveyor can result in a surface hardness of 40-45 Rockwell "C", or more.

Impact Resistance

The hard-facing alloy, in combination with the mild steel of the conveyor, results in excellent impact resistance. Large, abrasive, lumpy materials may be handled without undue wear, even at the conveyor inlet. Full-face application on the flight and pipe at the inlet will provide even better wear life.

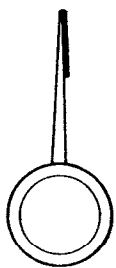

Helicoid

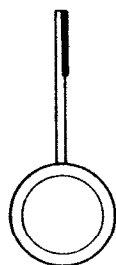

Sectional

WIDTH OF APPLICATION CHART

Screw Diameter	Width of Application
6	1
9	1-1/2
10	1-1/2
12	2
14	2
16	2-1/2
18	2-1/2
20	3
24	3

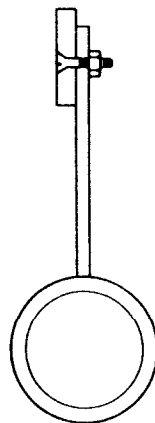

Detachable flight segment

Detachable flight segments, or wear shoes, bolted with counter-sunk bolts to the conveyor flights are preferred in many applications.

High carbon steels capable of heat treatment, or abrasion-resistant alloys are used to an ever increasing extent as materials for flights.

Corrosion-resistance conveyor screws

Corrosion is manifested in many different ways that no one choice of material will suit all requirements. To withstand the effects of corrosion encountered in many fields of industry, conveyor screws are fabricated of stainless steel, monel, and other materials.

Galvanizing, chrome plating and other coating methods have proved effective under mildly corrosive conditions. Mild steel conveyor screws serve effectively in many applications.

Heat-resistance conveyor screws

Conveyor screws for high temperature applications are made of heat-resistant alloys. Several of the stainless steels and other high-chrome alloys are particularly suitable for this service. Mild steel conveyor screws are also effective for use at moderately high temperatures.

HELICOID CONVEYOR SCREWS

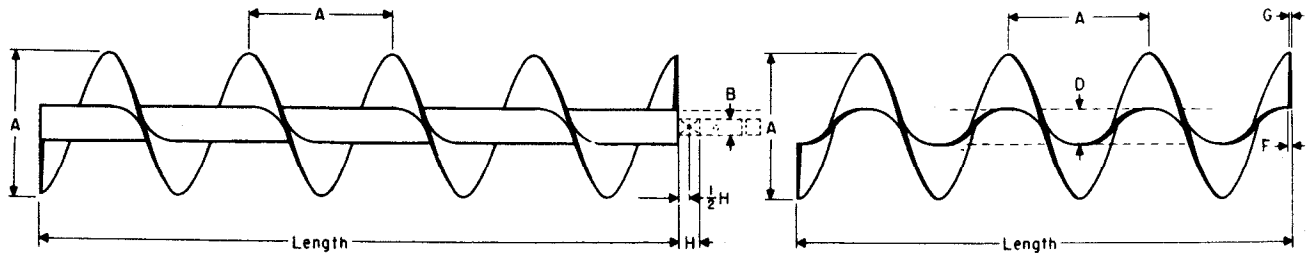

helicoid conveyor screw

flighting

A Screw Diam.	B Cplng. Diam.	Size Part No. Conveyor Mounted	Size Part No. Flighting Only	D Pipe Size		Flight Thickness		H Cplng. Bearing Length	Std. Length Ft.-In.	Average Weight			
				Inside	Outside	F Inside	G Outsd.			Complete Screw		Flighting Only	
										Std. Length	per Ft.	Std. Length	per Ft.
4	1 1	4H204.*	4HF204.*	1-1/4	1-5/8	1/8	1/16	1-1/2	9-10½	31	4	11	1.1
		4H206.*	4HF206.*	1-1/4	1-5/8	3/16	3/32	1-1/2	9-10½	40	5	16	2.0
6	1-1/2	6H304.*	6HF304.*	2	2-3/8	1/8	1/16	2	9-10	52	5	14	1.4
	1-1/2	6H308.*	6HF308.*	2	2-3/8	1/4	1/8	2	9-10	62	6	28	2.8
	1-1/2	6H312.*	6HF312.*	2	2-3/8	3/8	3/16	2	9-10	72	7	42	4.3
9	1-1/2	9H306.*	9HF306.*	2	2-3/8	3/16	3/32	2	9-10	70	7	31	3.2
	1-1/2	9H312.*	9HF312.*	2	2-3/8	3/8	3/16	2	9-10	101	10	65	6.6
	2	9H406.*	9HF406.*	2-1/2	2-7/8	3/16	3/32	2	9-10	91	9	30	3.0
	2	9H412.*	9HF412.*	2-1/2	2-7/8	3/8	3/16	2	9-10	121	12	60	6.1
	2	9H414.*	9HF414.*	2-1/2	2-7/8	7/16	7/32	2	9-10	131	13	70	7.0
10	1-1/2	10H306.*	10HF306.*	2	2-3/8	3/16	3/32	2	9-10	81	8	48	4.8
	2	10H412.*	10HF412.*	2-1/2	2-7/8	3/8	3/16	2	9-10	130	13	76	7.6
12	2	12H408.*	12HF408.*	2-1/2	2-7/8	1/4	1/8	2	11-10	140	12	67	5.7
	2	12H412.*	12HF412.*	2-1/2	2-7/8	3/8	3/16	2	11-10	180	15	102	8.6
	2-7/16	12H508.*	12HF508.*	3	3-1/2	1/4	1/8	3	11-9	168	14	64	5.4
	2-7/16	12H512.*	12HF512.*	3	3-1/2	3/8	3/16	3	11-9	198	17	96	8.2
	3	12H614.*	12HF614.*	3-1/2	4	7/16	7/32	3	11-9	220	18	105	8.8
14	2-7/16	14H508.*	14HF508.*	3	3-1/2	1/4	1/8	3	11-9	170	14	84	7.0
	3	14H614.*	14HF614.*	3-1/2	4	7/16	7/32	3	11-9	254	22	132	11.0
16	3	16H610.*	16HF610.*	3-1/2	4	5/16	5/32	3	11-9	228	19	120	10.0
	3	16H614.*	16HF614.*	4	4-1/2	7/16	7/32	3	11-9	270	22	144	12
18	3**	18H610-R	18HF610-R	3-1/2	4	5/16	5/32	3	11-9	282	24	167	14.2

- * - R For Right Hand
- L For Left Hand
- CF Cut Flight
- CFF Cut & Folded Flight
- CW1 Continuous Weld One Side
- CW2 Continuous Weld Two Sides
- AR Abrasion Resistant Flight
(for sectional flight only)

When ordering please specify length, right or left hand, pitch, material, and any other special features required.

** Only Available in right hand full pitch.

SECTIONAL CONVEYOR SCREWS

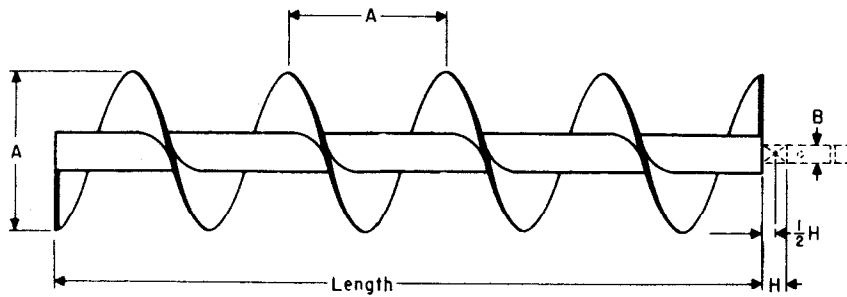

sectional conveyor screw

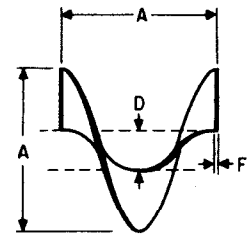

flight

A Screw Diam.	B Coupling Diam.	Size Part No. Mounted Conveyor	Size Part No. Flighting Only	Pipe Size		F Flight Thick- ness	H Cplng. Bearing Length	Std. Length Ft.-In.	Average Weight			Each Approx Flights per Ft.
				Inside	D Outside				Std. Length	per Ft.	Flight Each	
6	1-1/2	6 S309.*	6SF309.*	2	2-3/8	10 Ga.	2	9-10	65	6.5	1.3	2.0
	1-1/2	6 S312.*	6SF312.*	2	2-3/8	3/16	2	9-10	75	7.5	1.7	2.0
	1-1/2	6 S316.*	6SF316.*	2	2-3/8	1/4	2	9-10	87.6	8.9	2.4	2.0
9	1-1/2	9 S309.*	9SF309.*	2	2-3/8	10 Ga.	2	9-10	80	8.0	3.3	1.33
	1-1/2	9 S312.*	9SF312.*	2	2-3/8	3/16	2	9-10	95	9.5	4.3	1.33
	1-1/2	9 S316.*	9SF316.*	2	2-3/8	1/4	2	9-10	116	11.8	5.5	1.33
	1-1/2	9 S324.*	9SF324.*	2	2-3/8	3/8	2	9-10	155	15.9	8.8	1.33
	2	9 S409.*	9SF409.*	2-1/2	2-7/8	10 Ga.	2	9-10	100	10.0	3.3	1.33
	2	9 S412.*	9SF412.*	2-1/2	2-7/8	3/16	2	9-10	115	11.5	4.3	1.33
	2	9 S416.*	9SF416.*	2-1/2	2-7/8	1/4	2	9-10	130	13.0	5.5	1.33
	2	9 S424.*	9SF424.*	2-1/2	2-7/8	3/8	2	9-10	177	18.0	8.8	1.33
10	1-1/2	10 S309.*	10SF309.*	2	2-3/8	10 Ga.	2	9-10	85	8.5	3.9	1.2
	1-1/2	10 S312.*	10SF312.*	2	2-3/8	3/16	2	9-10	108	11.0	5.0	1.2
	1-1/2	10 S316.*	10SF316.*	2	2-3/8	1/4	2	9-10	132	13.4	7.7	1.2
	1-1/2	10 S324.*	10SF324.*	2	2-3/8	3/8	2	9-10	178	18.1	11.6	1.2
	2	10 S409.*	10SF409.*	2-1/2	2-7/8	10 Ga.	2	9-10	107	11.0	3.9	1.2
	2	10 S412.*	10SF412.*	2-1/2	2-7/8	3/16	2	9-10	120	12.0	5.0	1.2
	2	10 S416.*	10SF416.*	2-1/2	2-7/8	1/4	2	9-10	153	15.7	7.7	1.2
	2	10 S424.*	10SF424.*	2-1/2	2-7/8	3/8	2	9-10	199	21.2	11.6	1.2
12	2	12 S409.*	12SF409.*	2-1/2	2-7/8	10 Ga.	2	11-10	140	12.0	5.7	1.0
	2	12 S412.*	12SF412.*	2-1/2	2-7/8	3/16	2	11-10	156	13.0	7.2	1.0
	2	12 S416.*	12SF416.*	2-1/2	2-7/8	1/4	2	11-10	232	19.6	13.3	1.0
	2	12 S424.*	12SF424.*	2-1/2	2-7/8	3/8	2	11-10	306	25.8	19.5	1.0
	2-7/16	12 S509.*	12SF509.*	3	3-1/2	10 Ga.	3	11-9	160	14.0	5.7	1.0
	2-7/16	12 S512.*	12SF512.*	3	3-1/2	3/16	3	11-9	178	14.8	7.2	1.0
	2-7/16	12 S516.*	12SF516.*	3	3-1/2	1/4	3	11-9	210	17.5	9.7	1.0
	2-7/16	12 S524.*	12SF524.*	3	3-1/2	3/8	3	11-9	290	24.2	14.6	1.0
	3	12 S612.*	12SF612.*	3-1/2	4	3/16	3	11-9	184	15.4	7.2	1.0
	3	12 S616.*	12SF616.*	3-1/2	4	1/4	3	11-9	216	21.4	9.7	1.0
	3	12 S624.*	12SF624.*	3-1/2	4	3/8	3	11-9	280	26.7	12.7	1.0

* See Page 22

SECTIONAL CONVEYOR SCREWS

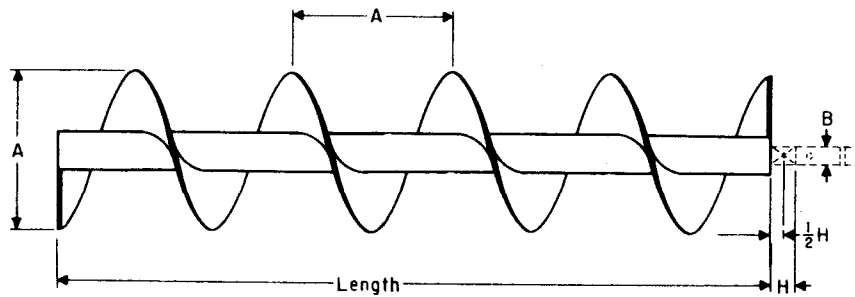

sectional conveyor screw

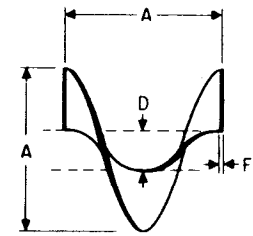

flight

A Screw Diam.	B Coupling Diam.	Size Part No. Mounted Conveyor	Size Part No. Flighting Only	Pipe Size		F Flight Thick- ness	H Cplng. Bearing Length	Std. Length Ft.-In.	Average Weight			Approx. Flights per Ft.
				Inside	D Outside				Std. Length	per Ft.	Flight Each	
14	2-7/16	14 S509.*	14SF509.*	3	3-1/2	10 Ga.	3	11-9	185	16	7.1	.86
	2-7/16	14 S512.*	14SF512.*	3	3-1/2	3/16	3	11-9	216	18.0	9.9	.86
	2-7/16	14 S516.*	14SF516.*	3	3-1/2	1/4	3	11-9	250	21.3	13.2	.86
	2-7/16	14 S524.*	14SF524.*	3	3-1/2	3/8	3	11-9	334	28.4	19.8	.86
	3	14 S612.*	14SF612.*	3-1/2	4	3/16	3	11-9	231	19.6	10.9	.86
	3	14 S616.*	14SF616.*	3-1/2	4	1/4	3	11-9	246	20.5	13.2	.86
16	3	14 S624.*	14SF624.*	3-1/2	4	3/8	3	11-9	342	28.5	19.8	.86
	3	16 S609.*	16SF609.*	3-1/2	4	10 Ga.	3	11-9	210	18	10.0	.75
	3	16 S612.*	16SF612.*	3-1/2	4	3/16	3	11-9	234	19.5	14.0	.75
	3	16 S616.*	16SF616.*	3-1/2	4	1/4	3	11-9	282	24	18.0	.75
	3	16 S624.*	16SF624.*	3-1/2	4	3/8	3	11-9	365	30.4	25.5	.75
18	3	16 S632.*	16SF632.*	3-1/2	4	1/2	3	11-9	420	36	34.5	.75
	3	18 S612.*	18SF612.*	3-1/2	4	3/16	3	11-9	246	20.5	18.0	.67
	3	18 S616.*	18SF616.*	3-1/2	4	1/4	3	11-9	294	24.5	24.0	.67
	3	18 S624.*	18SF624.*	3-1/2	4	3/8	3	11-9	425	35.5	34.5	.67
	3	18 S632.*	18SF632.*	3-1/2	4	1/2	3	11-9	530	44	46.0	.67
	3-7/16	18 S712.*	18SF712.*	4	4-1/2	3/16	4	11-8	293	24.4	18.0	.67
	3-7/16	18 S716.*	18SF716.*	4	4-1/2	1/4	4	11-8	345	28.8	24.0	.67
	3-7/16	18 S724.*	18SF724.*	4	4-1/2	3/8	4	11-8	470	39.2	34.5	.67
20	3-7/16	18 S732.*	18SF732.*	4	4-1/2	1/2	4	11-8	570	47.5	46.0	.67
	3	20 S612.*	20SF612.*	3-1/2	4	3/16	3	11-9	300	25.0	20.0	.60
	3	20 S616.*	20SF616.*	3-1/2	4	1/4	3	11-9	360	30.0	28.0	.60
	3	20 S624.*	20SF624.*	3-1/2	4	3/8	3	11-9	410	33.4	40.0	.60
	3	20 S632.*	20SF632.*	3-1/2	4	1/2	3	11-9	506	42.2	56.0	.60
	3-7/16	20 S712.*	20SF712.*	4	4-1/2	3/16	4	11-8	346	28.8	20.0	.60
	3-7/16	20 S716.*	20SF716.*	4	4-1/2	1/4	4	11-8	410	34.2	28.0	.60
	3-7/16	20 S724.*	20SF724.*	4	4-1/2	3/8	4	11-8	455	37.9	40.0	.60
24	3-7/16	20 S732.*	20SF732.*	4	4-1/2	1/2	4	11-8	550	45.9	56.0	.60
	3-7/16	24 S712.*	24SF712.*	4	4-1/2	3/16	4	11-8	440	37	32.0	.50
	3-7/16	24 S716.*	24SF716.*	4	4-1/2	1/4	4	11-8	510	43	42.0	.50
	3-7/16	24 S724.*	24SF724.*	4	4-1/2	3/8	4	11-8	595	50	63.0	.50
	3-7/16	24 S732.*	24SF732.*	4	4-1/2	1/2	4	11-8	690	60	84.0	.50

* See Page 22

RIBBON CONVEYOR SCREWS

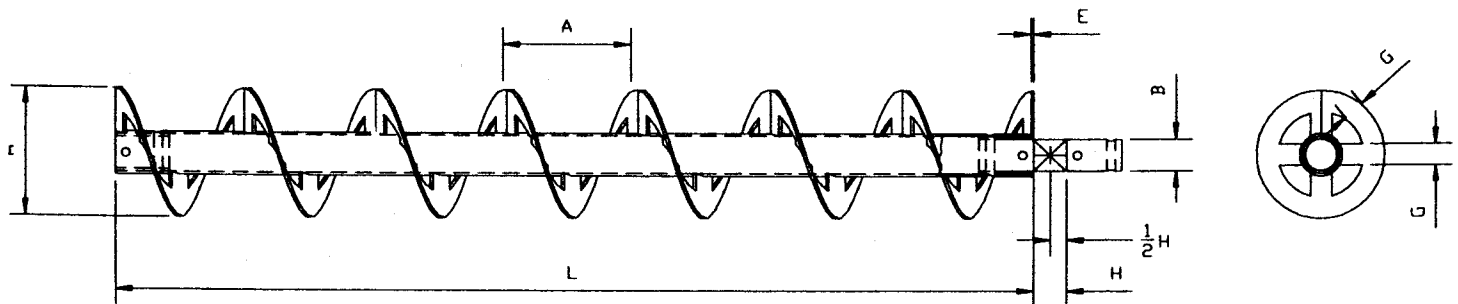

ribbon conveyor screw with pattern posts (shown)
Other styles of support posts available upon request.

STEEL

A Screw Diam.	B Cplng. Diam.	Size Part No. Mounted Conveyor	Size Part No. Flights Only	Pipe Size		Flight Size		H Cplng. Bearing Length	Std. Length Ft.-In.	Average Weight	
				Inside	Outside	Thickness E	G Width			Comp Screw	
										Std. Length	per Foot
6	1-1/2	6R312.*	6RF312.*	2	2-3/8	3/16	1	2	9-10	65	6.5
9	1-1/2	9R316.*	9RF316.*	2	2-3/8	1/4	1-1/2	2	9-10	100	10
10	1-1/2	10R316.*	10RF316.*	2	2-3/8	1/4	1-1/2	2	9-10	110	11
12	2	12R416.*	12RF416.*	2-1/2	2-7/8	1/4	2	2	11-10	180	15
	2	12R424.*	12RF424.*	2-1/2	2-7/8	3/8	2-1/2	2	11-10	216	18
	2-7/16	12R524.*	12RF524.*	3	3-1/2	3/8	2-1/2	3	11-9	240	20
14	2-7/16	14R516.*	14RF516.*	3	3-1/2	1/4	2	3	11-9	228	19
	2-7/16	14R524.*	14RF524.*	3	3-1/2	3/8	2-1/2	3	11-9	264	22
	3	14R624.*	14RF624.*	3-1/2	4	3/8	2-1/2	3	11-9	288	25
16	3	16R616.*	16RF616.*	3-1/2	4	1/4	2-1/2	3	11-9	276	24
	3	16R624.*	16RF624.*	3-1/2	4	3/8	2-1/2	3	11-9	324	28
18	3-7/16	18R724.*	18RF724.*	4	4-1/2	3/8	3	3	11-8	384	33
20	3-7/16	20R724.*	20RF724.*	4	4-1/2	3/8	3	4	11-8	408	35
24	3-7/16	24R724.*	24RF724.*	4	4-1/2	3/8	3	4	11-8	424	36

STAINLESS STEEL FINISHES

- Type CI-1 Remove weld splatter and scale.
- Type CI-2 Rough grind, if needed. Not sandblast, but cleaned.
- Type CI-3 Rough grind and sandblast.
- Type CI-4 Blend welds. No sandblast, and cleaned. (CEMA #2)
- Type CI-5 Blend welds and sandblast.
- Type CI-6 Blend welds, complete grind with 120 grit (CEMA #3), some pits and crevices permissible
- Type CI-7 Blend welds, complete grind with 120 grit, plus jeweler's rouge on all continuous welds (Commonly called Velvety Finish or CEMA #4) no pits or crevices permissible (FDA/USDA)
- Type CI-8 Blend welds, complete grind with 120 grit, plus Scotch Brite and Rouge (Commonly called Mirror Finish or CEMA #5) no pits or crevices permissible. (Dairy Products)

* See Page 22

SPECIAL CONVEYOR SCREWS

CUT FLIGHT

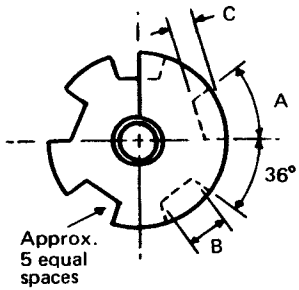
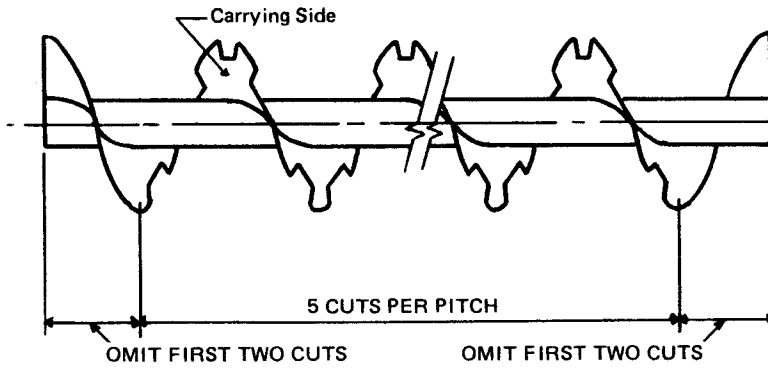

Depth of cut "C" is one half the flight width for normal pipe size. Lengths "A" & "B" are calculated from the developed O.D. for a standard pitch.

Screw Dia. Inches	A	B	C
	Inches		
4	1-3/8	1	5/8
6	2	1-1/2	7/8
9	3	2-1/8	1-1/2
10	3-3/8	2-1/4	1-3/4
12	4	2-3/4	2
14	4-5/8	3-1/8	2-1/2
16	5-1/4	3-1/2	2-1/2
18	6	3-7/8	3-3/8
20	6-5/8	4-1/4	3-7/8
24	7-7/8	4-7/8	4-7/8

CUT & FOLDED FLIGHT

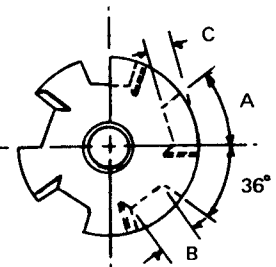
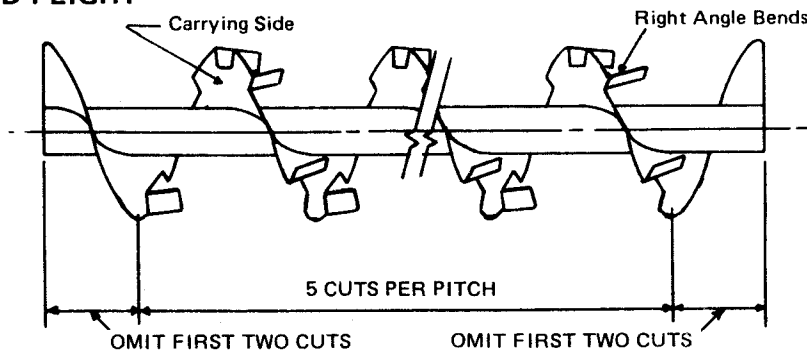

Depth of cut "C" is one half the flight width for normal pipe size. Lengths "A" & "B" are calculated from the developed O.D. for a standard pitch.

Screw Dia. Inches	A	B	C
	Inches		
4	1-3/8	1	5/8
6	2	1-1/2	7/8
9	3	2-1/8	1-1/2
10	3-3/8	2-1/4	1-3/4
12	4	2-3/4	2
14	4-5/8	3-1/8	2-1/2
16	5-1/4	3-1/2	3
18	6	3-7/8	3-3/8
20	6-5/8	4-1/4	3-7/8
24	7-7/8	4-7/8	4-7/8

SPECIAL CONVEYOR SCREWS



PADDLE

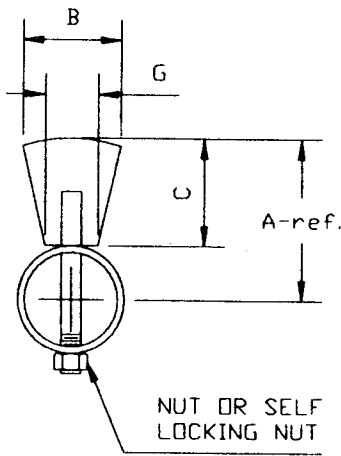
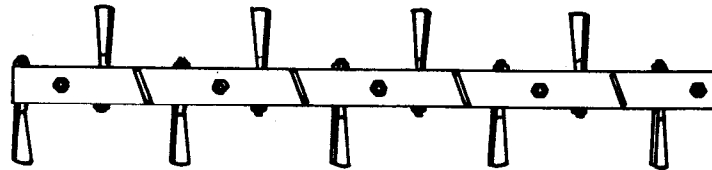
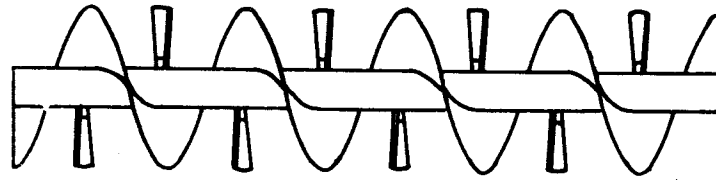

STYLE No. 1
ADJUSTABLE

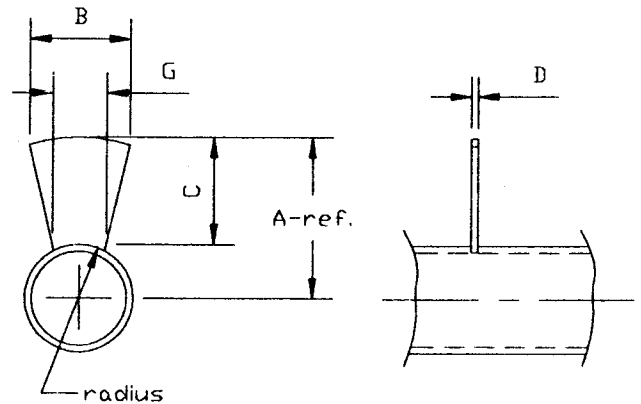

STYLE No. 2
WELDED

Screw Dia.	Part No.	Cplng. Dia.	Pipe Size		A	B	C	D	F	G	K	Wt. Each					
			Inside	Outside													
4	MP 42-*	1	1-1/4	1-5/8	2	1-1/2	1-3/16	3/16	3/8	7/8	1/2	.25					
6	MP 63-*	1-1/2	2	2-3/8	3	2-1/16	1-13/16	1/4	1/2	1-7/16	5/8	.50					
9	MP 93-*	1-1/2	2	2-3/8	4-1/2	2-3/4	3-5/16	1/4	1/2	1-1/2	5/8	.50					
	MP 94-*	2	2-1/2	2-7/8									3-1/16	5/8	1-5/8	3/4	.75
10	MP103-*	1-1/2	2	2-3/8	5	3-1/8	3-13/16	1/4	1/2	1-1/2	5/8	.75					
	MP104-*	2	2-1/2	2-7/8									3-9/16	5/8	1-5/8	3/4	1.00
12	MP124-*	2	2-1/2	2-7/8	6	3-11/16	4-9/16	3/8	5/8	1-3/4	3/4	1.50					
	MP125-*	2-7/16	3	3-1/2									4-1/16	5/8	1-7/8	3/4	1.75
	MP126-*	3	3-1/2	4									4	3/4	2	7/8	2.00
14	MP145-*	2-7/16	3	3-1/2	7	4-1/4	5-1/4	3/8	5/8	2	3/4	2.25					
	MP146-*	3	3-1/2	4									5	3/4	2-1/8	7/8	2.50
16	MP166-*	3	3-1/2	4	8	4-15/16	6	3/8	3/4	2-1/4	7/8	3.25					
	MP166X-*	3	4	4-1/2									5-3/4	7/8	2-3/8	1	3.50
18	MP186-*	3	3-1/2	4	9	5-3/8	7	3/8	3/4	2-1/8	7/8	4.00					
	MP187-*	3-7/16	4	4-1/2									6-3/4	7/8	2-1/4	1	4.25
20	MP206-*	3	3-1/2	4	10	6-1/8	8	3/8	3/4	2-7/16	7/8	4.75					
	MP207-*	3-7/16	4	4-1/2									7-3/4	7/8	2-9/16	1	5.00
24	MP247-*	3-7/16	4	4-1/2	12	7-3/8	9-3/4	1/2	7/8	2-11/16	1	6.75					

- *1 is style 1
- *2 is style 2

CONVEYOR SCREW COMPONENTS



Coupling Bolts

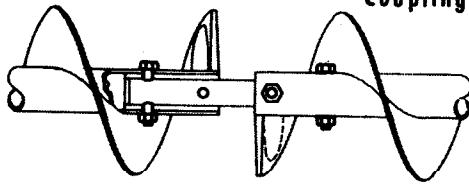

Coupling bolts are specially manufactured from high analysis steel to close tolerances. Due to short thread length, only the bolt shank is in contact with coupling and pipe ensuring full torque capacity and minimum wear.

A special lock type nut is provided with each coupling bolt.

Coupling Diameter	Pipe Diam.	Part No. Standard	Bolt Size	Weight each Lbs.
1	1-5/8	CB1	3/8 x 2-1/16	.13
1-1/2	2-3/8	CB112	1/2 x 3	.25
2	2-7/8	CB2	5/8 x 3-5/8	.50
2-7/16	3-1/2	CB2716	5/8 x 4-3/8	.56
3	4	CB3	3/4 x 5	.75
3	4-1/2	CB3A	3/4 x 5-1/2	.88
3-7/16	4-1/2	CB3716	7/8 x 5-1/2	1.25

Internal Collar

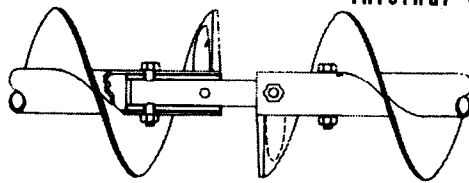

Internal collars are precision machined from high analysis steel tubing for a press fit into the conveyor pipe.

Replacement collars are provided without coupling bolt holes and should be field drilled to match existing bolt holes in pipe.

Coupling Diameter	Inside Pipe Diameter	Part No. Standard	Weight Each Lbs.
1	1-1/4	IC1	.7
1-1/2	2	IC112	2.2
2	2-1/2	IC2	2.4
2-7/16	3	IC2716	4.1
3	3-1/2	IC3	4.3
3	4	IC3A	8.3
3-7/16	4	IC3716	7.3

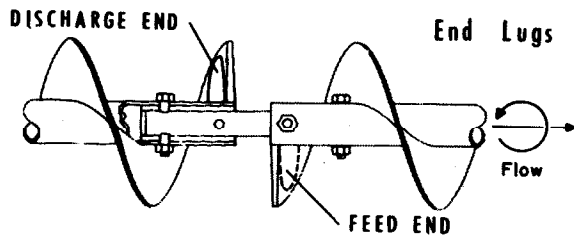

End Lugs

End lugs are formed with special dies from heavy gauge steel and are welded opposite the carrying face of the conveyor flight ends to prevent their deflection or distortion while presenting minimum obstruction to material flow.

Part numbers are established by diameter and hand of conveyor.

Conveyor Diameter	Part Number	Weight Each Lbs.
6	EL6-*	.06
9	EL9-*	.15
10	EL10-*	.15
12	EL12-*	.43
14	EL14-*	.43
16	EL16-*	.68
18	EL18-*	.68
20	EL20-*	.68
24	EL24-*	.68

* R For Right Hand Flight.

* L For Left Hand Flight.

SHAFTS



Coupling

Conveyor coupling shafts are required for connecting adjoining lengths of conveyor screws, to provide rotation and means for support through hanger bearings. All shafts are jig drilled for ease of assembly.

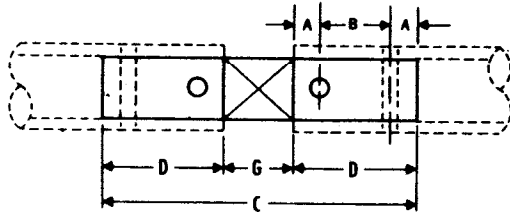

Shaft Diam.	Part Number	A	B	C	D	G	Weight
1	CS1-*	1/2	2	7-1/2	3	1-1/2	1.5
1-1/2	CS112-*	7/8	3	11-1/2	4-3/4	2	5.6
2	CS2-*	7/8	3	11-1/2	4-3/4	2	9.8
2-7/16	CS2716-*	15/16	3	12-3/4	4-7/8	3	15.4
3	CS3-*	1	3	13	5	3	23.8
3-7/16	CS3716-*	1-1/2	4	18	7	4	44.5

Close coupling

Close coupling shafts provide a means for connecting conveyor screws when it is not desirable to allow space for hanger bearings. Consideration should be given to the total unsupported length of screw to prevent deflection and whipping.

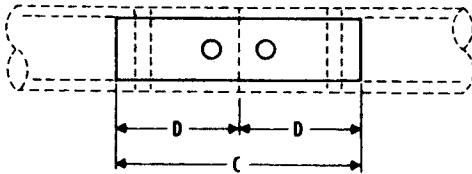

Shaft Dia.	Part Number Standard	C	D	Weight
1	CCS1-*	6	3	1.3
1-1/2	CCS112-*	9-1/2	4-3/4	4.8
2	CCS2-*	9-1/2	4-3/4	8.5
2-7/16	CCS2716-*	9-3/4	4-7/8	12.9
3	CCS3-*	10	5	20.0
3-7/16	CCS3716-*	14	7	37.0

End

End shafts serve only to support the end conveyor section and are therefore usually supplied in cold rolled steel. End shafts are jig drilled for ease of assembly and close diametral tolerances are held for proper bearing operation.

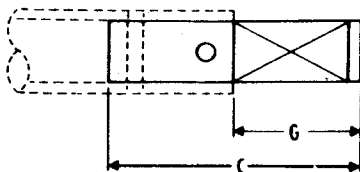

Shaft Diam.	Part Number	"C" Babbitt Bearing		"G" Babbitt Bearing		"C" Ball Bearing		"G" Ball Bearing	Wt.
		W/Seal BS	Without B	W/Seal BBS	Without BB	W/Seal BBS	Without BB		
1-1/2	ES112*	11	9-1/4	6-1/4	10	8-1/4	5-1/4	4.8	
2	ES2*	12	10-1/4	7-1/4	10-3/8	8-1/2	5-5/8	9.4	
2-7/16	ES2716*	13-5/8	11-7/8	8-3/4	11-3/8	9-5/8	6-1/2	14.9	
3	ES3*	14-7/8	13-1/8	9-7/8	12-3/8	10-5/8	7-3/8	24.0	
3-7/16	ES3716*	18-3/4	16-1/2	11-3/8	15-5/8	13-3/8	8-3/8	37.0	

-* H Hardened
-* S Stellite Brng. Area

-* SS Stainless Steel (Specify Type)
-* 3 for special three bolt connection
-* 4 for special four bolt connection

□ Standard. Furnished unless otherwise specified.

- BS for Babbit Bearing, lengthened for seal
- B for Babbit Bearing, no seal
- BBS for Ball Bearing, lengthened for seal
- BB for Ball Bearing, no seal

SHAFTS



Hanger end

Hanger end shafts are designed to connect only one conveyor section to a hanger bearing. These shafts may also be used in pairs to divide an excessively long conveyor assembly between two drives.

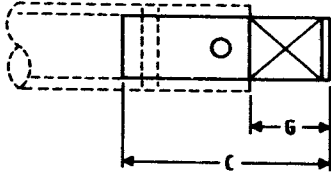

Shaft Diam.	Part Number Standard	C	G	Wt.
1	HES1-*	4-5/8	1-5/8	1.0
1-1/2	HES112-*	6-7/8	2-1/8	3.5
2	HES2-*	6-7/8	2-1/8	6.2
2-7/16	HES2716-*	8-1/8	3-1/4	10.6
3	HES3-*	8-1/4	3-1/4	16.5
3-7/16	HES3716-*	11-1/4	4-1/4	29.7

No. 1 Drive

Number 1 drive shafts are the most frequently used means of connecting driving power to a conveyor assembly through all but the outboard type conveyor ends. Diameter and keyway dimensions are held to close tolerances for ease of assembly.

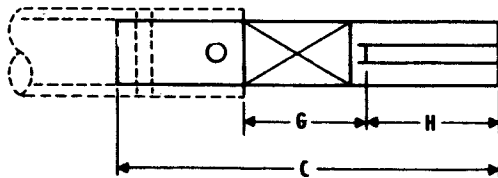

Shaft Dia.	Part Number	"C" Babbitt Bearing		"G" Babbitt Bearing	"C" Ball Bearing		"G" Ball Bearing	H	Wt.
		W/Seal BS	W/out Seal B		W/Seal BBS □	W/out Seal BB			
1	DS1-*	10-1/4	8-1/2	5-1/4	9-3/4	8	4-3/4	2	2.0
1-1/2	DS112-*	14-1/4	12-1/2	6-3/4	13-1/4	11-1/2	5-3/4	2-3/4	6.5
2	DS2-*	16-1/2	14-3/4	8-1/2	14-7/8	13-1/8	6-7/8	3-1/4	13.0
2-7/16	DS2716-*	19-1/8	17-3/8	10	16-7/8	15-1/8	7-3/4	4-1/4	21.0
3	DS3-*	20-7/8	19-1/8	11-1/8	18-3/8	16-5/8	8-5/8	4-3/4	36.0
3-7/16	DS3716-*	25-5/8	23-3/8	12-7/8	22-5/8	20-3/8	9-7/8	5-3/4	55.0

No. 2 Drive

Number 2 drive shafts are specifically designed for use with the single outboard bearing type of conveyor ends. Jig drilling and close tolerances assure rapid assembly in the field.

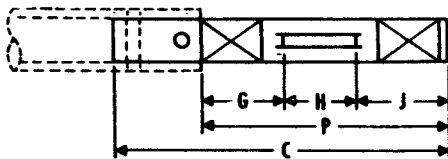

Shaft Diam.	Part Number	C	G	H	J	P	Weight
1	DS-2-1-*	11	3-1/4	2-1/4	2-1/2	8	2.5
1-1/2	DS-2-112-*	16-1/2	5	3-1/4	3-1/2	11-3/4	8.3
2	DS-2-2-*	18-3/4	5-1/4	4-1/4	4-1/2	14	17.0
2-7/16	DS-2-2716-*	21-7/8	6	5-1/2	5-1/2	17	29.0
3	DS-2-3-*	23-1/2	6-1/2	5-1/2	6-1/2	18-1/2	49.0
3-7/16	DS-2-3716-*	27	6-3/4	6	7-1/2	20-1/4	75.0

No. 3 Drive

Number 3 drive shafts are for use with the double outboard type of conveyor ends. Carefully controlled dimensional tolerances assure proper alignment between the two end bearings.

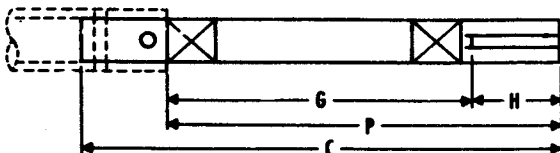

Shaft Dia.	Part Number	C	G	H	P	Wt.
1	DS-3-1-*	13	7-3/4	2-1/4	10	3
1-1/2	DS-3-112-*	19-1/4	11-1/4	3-1/4	14-1/2	10
2	DS-3-2-*	25-1/4	16-1/4	4-1/4	20-1/2	21
2-7/16	DS-3-2716-*	28-7/8	18-3/4	5-1/4	24	36
3	DS-3-3-*	33-1/2	22-1/4	6-1/4	28-1/2	62
3-7/16	DS-3-3716-*	39-1/4	25-1/4	7-1/4	32-1/2	95

- * H Hardened
- * SS Stainless Steel (Specify Type)
- * S Stellite Brng. Area
- * 3 for special three bolt connection
- * 4 for special four bolt connection

□ Standard. Furnished unless otherwise specified.

- BS for Babbitt Bearing lengthened for seal
- B for Babbitt Bearing, no seal
- BBS for Ball Bearing, lengthened for seal
- BB for Ball Bearing, no seal

OIL PIPES AND GREASE FITTINGS ARE REQUIRED WITH ALL BALL BEARING HANGERS (STYLE #60 AND #70)

HANGERS

STYLE 60

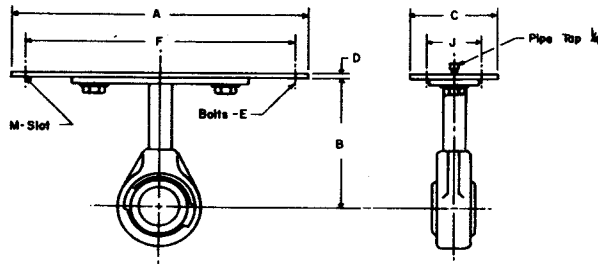
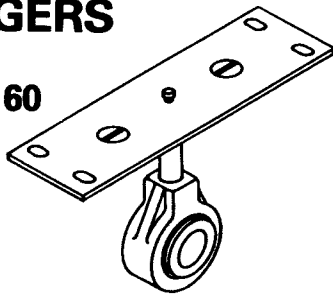

Conveyor Diam.	Coupling Diameter	▲ Part Number	A	B	C	D	E	F	J	Weight Each	M Slot
6	1-1/2	H660112	9-3/4	4-1/2	4	1/4	3/8	8-3/4	2-1/2	7	7/16
9	1-1/2 2	H960112	13-1/2	6-1/8	4	1/4	3/8	12-1/4	2-1/2	8	7/16
		H9602		6-1/8				12-1/4		9	
10	1-1/2 2	H1060112	14-1/2	6-3/8	4	1/4	3/8	13-1/4	2-1/2	9	7/16
		H10602		6-3/8				13-1/4		10	
12	2 2-7/16 3	H12602	17-1/2	7-3/4	5	3/8	1/2	15-3/4	2-1/2	12	9/16
		H12602716		7-3/4				15-3/4		20	
		H12603		7-3/4				15-3/4		30	
14	2-7/16 3	H14602716	19-1/2	9-1/4	5	3/8	1/2	17-3/4	2-1/2	21	9/16
		H14603		9-1/4				17-3/4		32	
16	3	H16603	21-1/2	10-5/8	5	3/8	1/2	19-3/4	2-1/2	35	9/16
18	3 3-7/16	H18603	24-1/2	12-1/8	5	1/2	5/8	22-1/4	3-1/2	40	11/16
		H18603716	24-1/2	12-1/8	5	1/2	5/8	22-1/4	3-1/2	40	11/16
20	3 3-7/16	H20603	26-1/2	13-1/2	5	1/2	5/8	24-1/4	3-1/2	45	11/16
		H20603716	26-1/2	13-1/2	5	1/2	5/8	24-1/4	3-1/2	45	11/16
24	3-7/16	H24603716	30-1/2	16-1/2	5	1/2	5/8	28-1/4	3-1/2	45	11/16

STYLE 70

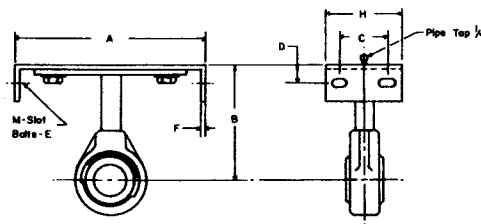
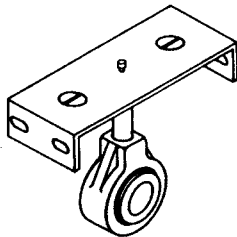

Conveyor Diam.	Coupling Diam.	▲ Part Number	A	B	C	D	E	F	H	Weight Each	M Slot
6	1-1/2	H670112	7	4-1/2	2-1/2	3/4	3/8	1/4	4	7	7/16
9	1-1/2 2	H970112	10	6-1/8	2-1/2	1	3/8	1/4	4	8	7/16
		H9702	10	6-1/8	2-1/2	1	3/8	1/4	4	9	
10	1-1/2 2	H1070112	11	6-3/8	2-1/2	1	3/8	1/4	4	9	7/16
		H10702	11	6-3/8	2-1/2	1	3/8	1/4	4	10	
12	2 2-7/16 3	H12702	13	7-3/4	2-1/2	1-1/4	1/2	3/8	5	12	9/16
		H12702716	13	7-3/4	2-1/2	1-1/4	1/2	3/8	5	20	
		H12703	13	7-3/4	2-1/2	1-1/4	1/2	3/8	5	30	
14	2-7/16 3	H14702716	15	9-1/4	2-1/2	1-3/8	1/2	3/8	5	21	9/16
		H14703	15	9-1/4	2-1/2	1-3/8	1/2	3/8	5	32	
16	3	H16703	17	10-5/8	2-1/2	1-3/8	1/2	3/8	5	35	9/16
18	3 3-7/16	H18703	19	12-1/8	3-1/2	1-5/8	5/8	1/2	5	40	11/16
		H18703716	19	12-1/8	3-1/2	1-5/8	5/8	1/2	5	40	11/16
20	3 3-7/16	H20703	21	13-1/2	3-1/2	1-5/8	5/8	1/2	5	45	11/16
		H20703716	21	13-1/2	3-1/2	1-5/8	5/8	1/2	5	45	11/16
24	3-7/16	H24703716	25	16-1/2	3-1/2	1-3/4	5/8	1/2	5	45	11/16

▲ Hanger Frame Assembly can be furnished in fabricated stainless steel. Specify type.

OIL PIPES AND GREASE FITTINGS ARE SUPPLIED AS BEARING MATERIAL DICTATES OR UPON REQUEST.

HANGERS

STYLE 216

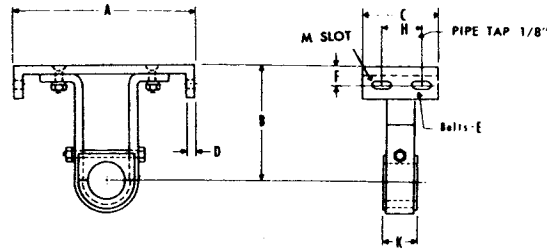
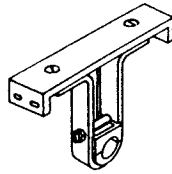

Conveyor Diameter	Coupling Size	▲ Part Number	A	B	C	D	E	F	H	K	M Slot	Weight Each
6	1-1/2	H6216112-*	7	4-1/2	4	1/4	3/8	3/4	2-1/2	2	7/16	5
9	1-1/2 2	H9216112-*	10	6-1/8	4	1/4	3/8	1	2-1/2	2	7/16	7
		H92162-*	10	6-1/8	4	1/4	3/8	1	2-1/2	2	7/16	9
10	1-1/2 2	H10216112-*	11	6-3/8	4	1/4	3/8	1	2-1/2	2	7/16	8
		H102162-*	11	6-3/8	4	1/4	3/8	1	2-1/2	2	7/16	10
12	2 2-7/16 3	H122162-*	13	7-3/4	5	3/8	1/2	1-1/4	2-1/2	2	9/16	14
		H122162716-*	13	7-3/4	5	3/8	1/2	1-1/4	2-1/2	3		18
		H122163-*	13	7-3/4	5	3/8	1/2	1-1/4	2-1/2	3		21
14	2-7/16 3	H142162716-*	15	9-1/4	5	3/8	1/2	1-3/8	2-1/2	3	9/16	23
		H142163-*	15	9-1/4	5	3/8	1/2	1-3/8	2-1/2	3		25
16	3	H162163-*	17	10-5/8	5	3/8	1/2	1-3/8	2-1/2	3	9/16	28
18	3 3-7/16	H182163-*	19	12-1/8	5	1/2	5/8	1-5/8	3-1/2	3	11/16	34
		H182163716-*	19	12-1/8	5	1/2	5/8	1-5/8	3-1/2	4		44
20	3 3-7/16	H202163-*	21	13-1/2	5	1/2	5/8	1-5/8	3-1/2	3	11/16	36
		H202163716-*	21	13-1/2	5	1/2	5/8	1-5/8	3-1/2	4		47
24	3-7/16	H242163716-*	25	16-1/2	5	1/2	5/8	1-3/4	3-1/2	4	11/16	53

STYLE 220

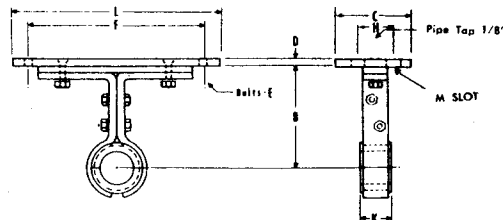
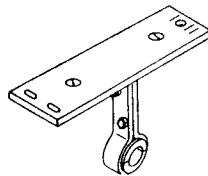

Conveyor Diameter	Coupling Size	▲ Part Number	B	C	D	E	F	H	K	L	M Slot	Weight Each
4	1	H42201-*	3-5/8	4	1/4	1/4	6-1/4	2	1-1/2	7-1/4	5/16	5
6	1-1/2	H6220112-*	4-1/2	4	1/4	3/8	8-3/4	2-1/2	2	9-3/4	7/16	7
9	1-1/2 2	H9220112-*	6-1/8	4	1/4	3/8	12-1/4	2-1/2	2	13-1/2	7/16	9
		H92202-*	6-1/8	4	1/4	3/8	12-1/4	2-1/2	2	13-1/2		11
10	1-1/2 2	H10220112-*	6-3/8	4	1/4	3/8	13-1/4	2-1/2	2	14-1/2	7/16	10
		H102202-*	6-3/8	4	1/4	3/8	13-1/4	2-1/2	2	14-1/2		12
12	2 2-7/16 3	H122202-*	7-3/4	5	3/8	1/2	15-3/4	2-1/2	2	17-1/2	9/16	16
		H122202716-*	7-3/4	5	3/8	1/2	15-3/4	2-1/2	3	17-1/2		21
		H122203-*	7-3/4	5	3/8	1/2	15-3/4	2-1/2	3	17-1/2		28
14	2-7/16 3	H142202716-*	9-1/4	5	3/8	1/2	17-3/4	2-1/2	3	19-1/2	9/16	26
		H142203-*	9-1/4	5	3/8	1/2	17-3/4	2-1/2	3	19-1/2		33
16	3	H162203-*	10-5/8	5	3/8	1/2	19-3/4	2-1/2	3	21-1/2	9/16	39
18	3 3-7/16	H182203-*	12-1/8	5	1/2	5/8	22-1/4	3-1/2	3	24-1/2	11/16	41
		H182203716-*	12-1/8	5	1/2	5/8	22-1/4	3-1/2	4	24-1/2		49
20	3 3-7/16	H202203-*	13-1/2	5	1/2	5/8	24-1/4	3-1/2	3	26-1/2	11/16	43
		H202203716-*	13-1/2	5	1/2	5/8	24-1/4	3-1/2	4	26-1/2		51
24	3-7/16	H242203716-*	16-1/2	5	1/2	5/8	28-1/4	3-1/2	4	30-1/2	11/16	57

* See P. 37 For Complete Part No. Information

▲ Hanger Frame Assembly Can Be Furnished In Stainless Steel. Specify Type.

OIL PIPES AND GREASE FITTINGS ARE SUPPLIED AS BEARING MATERIAL DICTATES OR UPON REQUEST.



HANGERS

STYLE 226

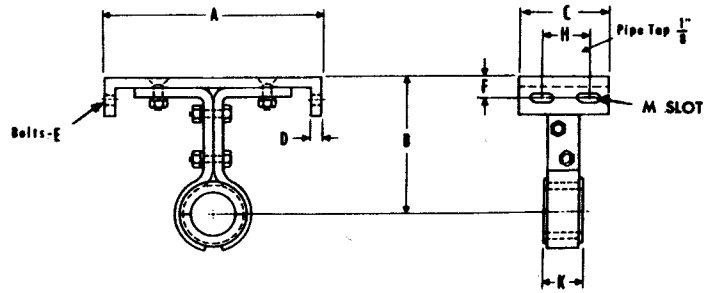
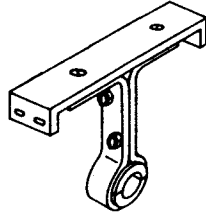

Conveyor Diameter	Coupling Size	▲ Part Number	A	B	C	D	E	F	H	K	M Slot	Weight Each
4	1	H42261-*	5	3-5/8	4	1/4	1/4	5/8	2	1-1/2	5/16	4
6	1-1/2	H6226112-*	7	4-1/2	4	1/4	3/8	3/4	2-1/2	2	7/16	6
9	1-1/2 2	H9226112-*	10	6-1/8	4	1/4	3/8	1	2-1/2	2	7/16	8
		H92262-*	10	6-1/8	4	1/4	3/8	1	2-1/2	2		9
10	1-1/2 2	H10226112-*	11	6-3/8	4	1/4	3/8	1	2-1/2	2	7/16	9
		H102262-*	11	6-3/8	4	1/4	3/8	1	2-1/2	2		11
12	2 2-7/16 3	H122262-*	13	7-3/4	5	3/8	1/2	1-1/4	2-1/2	2	9/16	13
		H122262716-*	13	7-3/4	5	3/8	1/2	1-1/4	2-1/2	3		18
		H122263-*	13	7-3/4	5	3/8	1/2	1-1/4	2-1/2	3		24
14	2-7/16 3	H142262716-*	15	9-1/4	5	3/8	1/2	1-3/8	2-1/2	3	9/16	22
		H142263-*	15	9-1/4	5	3/8	1/2	1-3/8	2-1/2	3		29
16	3	H162263-*	17	10-5/8	5	3/8	1/2	1-3/8	2-1/2	3	9/16	34
18	3 3-7/16	H182263-*	19	12-1/8	5	1/2	5/8	1-5/8	3-1/2	3	11/16	35
		H182263716-*	19	12-1/8	5	1/2	5/8	1-5/8	3-1/2	4		46
20	3 3-7/16	H202263-*	21	13-1/2	5	1/2	5/8	1-5/8	3-1/2	3	11/16	41
		H202263716-*	21	13-1/2	5	1/2	5/8	1-5/8	3-1/2	4		52
24	3-7/16	H242263716-*	25	16-1/2	5	1/2	5/8	1-3/4	3-1/2	4	11/16	63

STYLE 230

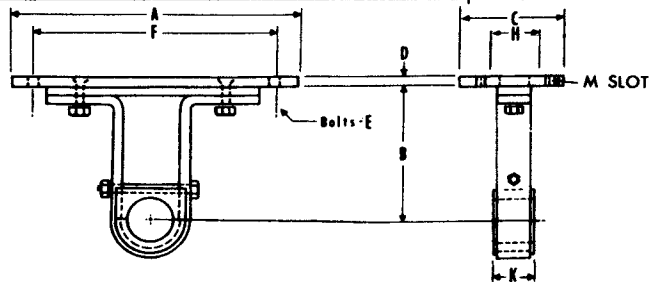
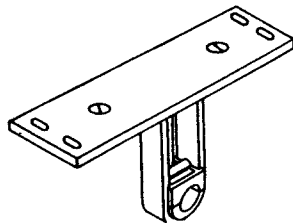

Conveyor Diameter	Coupling Size	▲ Part Number	A	B	C	D	E	F	H	K	M Slot	Weight Each
6	1-1/2	H6230112-*	5-3/4	4-1/2	4	1/4	3/8	8-3/4	2-1/2	2	7/16	6
9	1-1/2 2	H9230112-*	13-1/2	6-1/8	4	1/4	3/8	12-1/4	2-1/2	2	7/16	8
		H92302-*	13-1/2	6-1/8	4	1/4	3/8	12-1/4	2-1/2	2		10
10	1-1/2 2	H10230112-*	14-1/2	6-3/8	4	1/4	3/8	13-1/4	2-1/2	2	7/16	9
		H102302-*	14-1/2	6-3/8	4	1/4	3/8	13-1/4	2-1/2	2		11
12	2 2-7/16 3	H122302-*	17-1/2	7-3/4	5	3/8	1/2	15-3/4	2-1/2	2	9/16	15
		H122302716-*	17-1/2	7-3/4	5	3/8	1/2	15-3/4	2-1/2	3		20
		H122303-*	17-1/2	7-3/4	5	3/8	1/2	15-3/4	2-1/2	3		25
14	2-7/16 3	H142302716-*	19-1/2	9-1/4	5	3/8	1/2	17-3/4	2-1/2	3	9/16	24
		H142303-*	19-1/2	9-1/4	5	3/8	1/2	17-3/4	2-1/2	3		29
16	3	H162303-*	21-1/2	10-5/8	5	3/8	1/2	19-3/4	2-1/2	3	9/16	35
18	3 3-7/16	H182303-*	24-1/2	12-1/8	5	1/2	5/8	22-1/4	3-1/2	3	11/16	34
		H182303716-*	24-1/2	12-1/8	5	1/2	5/8	22-1/4	3-1/2	4		47
20	3 3-7/16	H202303-*	26-1/2	13-1/2	5	1/2	5/8	24-1/4	3-1/2	3	11/16	40
		H202303716-*	26-1/2	13-1/2	5	1/2	5/8	24-1/4	3-1/2	4		49
24	3-7/16	H242303716-*	30-1/2	16-1/2	5	1/2	5/8	28-1/4	3-1/2	4	11/16	55

* See P. 37 For Complete Part No. Information

▲ Hanger Frame Assembly Can Be Furnished In Stainless Steel. Specify Type.

OIL PIPES AND GREASE FITTINGS ARE SUPPLIED AS BEARING MATERIAL DICTATES OR UPON REQUEST.

HANGERS-FLARED

STYLE 216-F

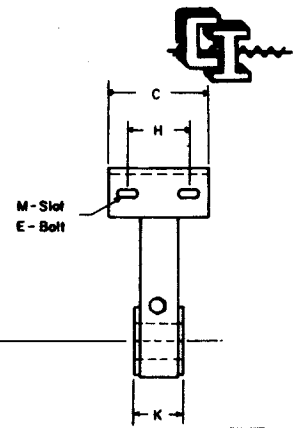
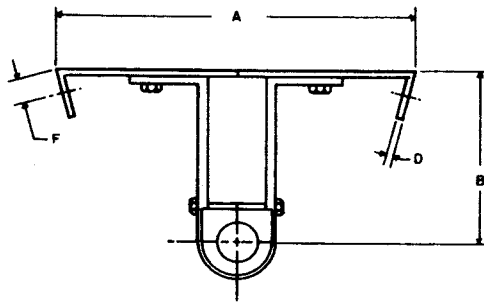
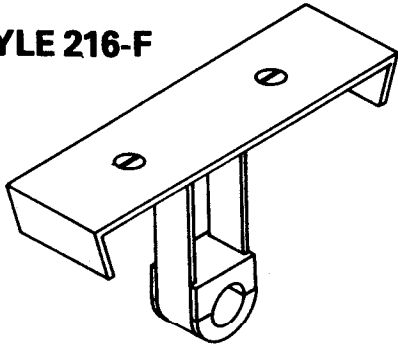

Conveyor Diameter	Coupling Size	Part Number	A	B	C	D	E	F	H	K	Weight Each	M Slot
6	1-1/2	H6216112F-*	14	7	4	1/4	3/8	7/8	2-1/2	2	9	7/16
9	1-1/2 2	H9216112F-*	18	9	4	1/4	3/8	7/8	2-1/2	2	14	7/16
		H92162F-*									17	
12	2 2-7/16 3	H122162F-*	22	10	5	3/8	1/2	1-1/8	2-1/2	2	24	9/16
		H122162716F-*									28	
		H122163F-*									32	
14	2-7/16 3	H142162716F-*	24	11	5	3/8	1/2	1-1/8	2-1/2	3	31	9/16
		H142163F-*									34	
16	3	H162163F-*	28	11-1/2	5	3/8	1/2	1-1/8	2-1/2	3	38	9/16
18	3 3-7/16	H182163F-*	31	12-1/8	5	1/2	5/8	1-1/2	3-1/2	3	52	11/16
		H182163716F-*									61	
20	3 3-7/16	H202163F-*	34	13-1/2	5	1/2	5/8	1-1/2	3-1/2	3	55	11/16
		H202163716F-*									64	
24	3-7/16	H242163716F-*	40	16-1/2	5	1/2	5/8	1-1/2	3-1/2	4	71	11/16

STYLE 226-F

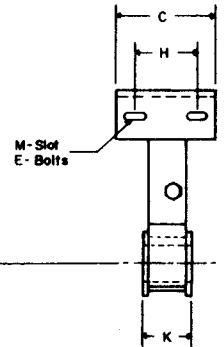
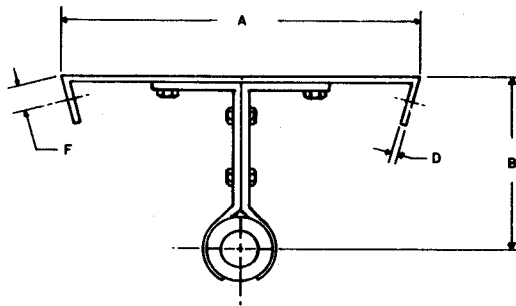
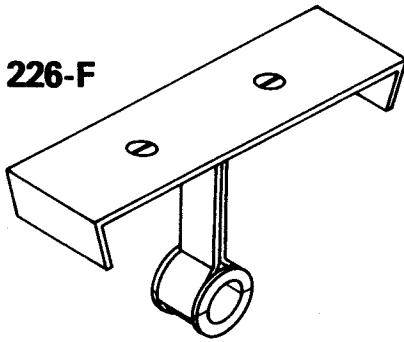

Conveyor Diameter	Coupling Size	Part Number	A	B	C	D	E	F	H	K	Weight Each	M Slot
6	1-1/2	H6226112F-*	14	7	4	1/4	3/8	7/8	2-1/2	2	9	7/16
9	1-1/2 2	H9226112F-*	18	9	4	1/4	3/8	7/8	2-1/2	2	14	7/16
		H92262F-*									17	
12	2 2-7/16 3	H122262F-*	22	10	5	3/8	1/2	1-1/8	2-1/2	2	24	9/16
		H122262716F-*									28	
		H122263F-*									32	
14	2-7/16 3	H142262716F-*	24	11	5	3/8	1/2	1-1/8	2-1/2	3	31	9/16
		H142263F-*									34	
16	3	H162263F-*	28	11-1/2	5	3/8	1/2	1-1/8	2-1/2	3	38	9/16
18	3 3-7/16	H182263F-*	31	12-1/8	5	1/2	5/8	1-1/2	3-1/2	3	52	11/16
		H182263716F-*									61	
20	3 3-7/16	H202263F-*	34	13-1/2	5	1/2	5/8	1-1/2	3-1/2	3	55	11/16
		H202263716F-*									64	
24	3-7/16	H242263716F-*	40	16-1/2	5	1/2	5/8	1-1/2	3-1/2	4	71	11/16

* See Page 37 for complete Part No. information.
 ▲ Hanger frame assembly can be furnished in stainless steel specify type.

HANGERS STYLE 326 EXPANSION

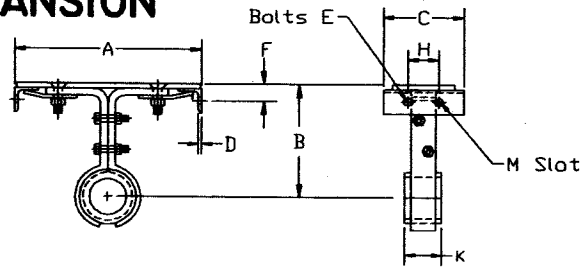

CONVEYOR DIAMETER	COUPLING SIZE	▲ PART NUMBER	A	B	C	D	E	F	H	K	M SLOT
6	1 1/2	H6326112- *	7	4 1/2	6	3/16	3/8	3/4	2 1/2	2	7/16
9	1 1/2 2	H9326112- *	10	6 1/8	6	3/16	3/8	1	2 1/2	2	7/16
		H93262- *	10	6 1/8	6	3/16	3/8	1	2 1/2	2	7/16
10	1 1/2 2	H10326112- *	11	6 3/8	6	3/16	3/8	1	2 1/2	2	7/16
		H103262- *	11	6 3/8	6	3/16	3/8	1	2 1/2	2	7/16
12	2 2 7/16 3	H123262- *	13	7 3/4	6 1/2	3/16	1/2	1 1/4	2 1/2	2	9/16
		H123262716- *	13	7 3/4	6 1/2	3/16	1/2	1 1/4	2 1/2	3	
		H123263- *	13	7 3/4	6 1/2	3/16	1/2	1 1/4	2 1/2	3	
14	2 7/16 3	H143262716- *	15	9 1/4	6 1/2	3/16	1/2	1 3/8	2 1/2	3	9/16
		H143263- *	15	9 1/4	6 1/2	3/16	1/2	1 3/8	2 1/2	3	
16	3	H163263- *	17	10 5/8	6 1/2	3/16	1/2	1 3/8	2 1/2	3	9/16
18	3 3 7/16	H183263- *	19	12 1/8	6 1/2	3/16	5/8	1 5/8	3 1/2	3	11/16
		H183263716- *	19	12 1/8	6 1/2	3/16	5/8	1 5/8	3 1/2	4	
20	3 3 7/16	H203263- *	21	13 1/2	6 1/2	3/16	5/8	1 5/8	3 1/2	3	11/16
		H203263716- *	21	13 1/2	6 1/2	3/16	5/8	1 5/8	3 1/2	4	
24	3 7/16	H243263716- *	25	16 1/2	7	3/16	5/8	1 3/4	3 1/2	4	11/16

STYLE 316 EXPANSION

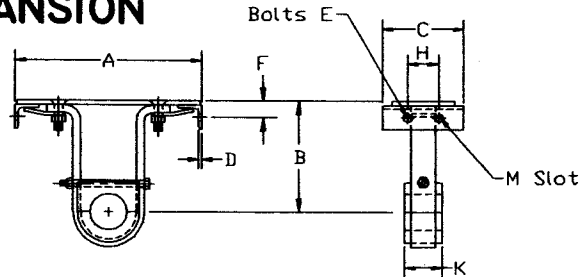

CONVEYOR DIAMETER	COUPLING SIZE	▲ PART NUMBER	A	B	C	D	E	F	H	K	M SLOT
6	1 1/2	H6316112- *	7	4 1/2	6	3/16	3/8	3/4	2 1/2	2	7/16
9	1 1/2 2	H9316112- *	10	6 1/8	6	3/16	3/8	1	2 1/2	2	7/16
		H93162- *	10	6 1/8	6	3/16	3/8	1	2 1/2	2	7/16
10	1 1/2 2	H10316112- *	11	6 3/8	6	3/16	3/8	1	2 1/2	2	7/16
		H103162- *	11	6 3/8	6	3/16	3/8	1	2 1/2	2	7/16
12	2 2 7/16 3	H123162- *	13	7 3/4	6 1/2	3/16	1/2	1 1/4	2 1/2	2	9/16
		H123162716- *	13	7 3/4	6 1/2	3/16	1/2	1 1/4	2 1/2	3	
		H123163- *	13	7 3/4	6 1/2	3/16	1/2	1 1/4	2 1/2	3	
14	2 7/16 3	H143162716- *	15	9 1/4	6 1/2	3/16	1/2	1 3/8	2 1/2	3	9/16
		H143163- *	15	9 1/4	6 1/2	3/16	1/2	1 3/8	2 1/2	3	
16	3	H163163- *	17	10 5/8	6 1/2	3/16	1/2	1 3/8	2 1/2	3	9/16
18	3 3 7/16	H183163- *	19	12 1/8	6 1/2	3/16	5/8	1 5/8	3 1/2	3	11/16
		H183163716- *	19	12 1/8	6 1/2	3/16	5/8	1 5/8	3 1/2	4	
20	3 3 7/16	H203163- *	21	13 1/2	6 1/2	3/16	5/8	1 5/8	3 1/2	3	11/16
		H203163716- *	21	13 1/2	6 1/2	3/16	5/8	1 5/8	3 1/2	4	
24	3 7/16	H243163716- *	25	16 1/2	7	3/16	5/8	1 3/4	3 1/2	4	11/16

* See P. 37 for complete part no. information
 ▲ Hanger Frame Assembly can be furnished in stainless steel. Specify type

HANGERS STYLE 30

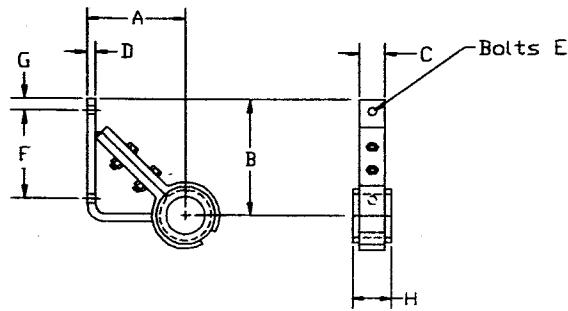

CONVEYOR DIAMETER	COUPLING SIZE	▲ PART NUMBER	A	B	C	D	E	F	G	H
6	1 1/2	H630112- *	3 1/2	4 1/4	1 1/2	3/8	5/16	3 1/2	1/2	2
9	1 1/2	H930112- *	5	5 7/8	1 1/2	3/8	3/8	4 1/4	1/2	2
	2	H9302- *	5	5 7/8	1 1/2	1/2	3/8	4 1/4	1/2	2
10	1 1/2	H1030112- *	5 1/2	6 3/8	1 3/4	3/8	1/2	4 3/8	3/4	2
	2	H10302- *	5 1/2	6 3/8	1 3/4	1/2	1/2	4 3/8	3/4	2
12	2	H12302- *	6 1/2	7 1/2	2	1/2	1/2	5 1/2	3/4	2
	2 7/16	H12302716- *	6 1/2	7 1/2	2 1/4	1/2	1/2	5 1/2	3/4	3
	3	H12303- *	6 1/2	7 1/2	2 1/4	5/8	1/2	5 1/2	3/4	3
14	2 7/16	H14302716- *	7 1/2	9	2 1/4	1/2	5/8	6 7/8	7/8	3
	3	H14303- *	7 1/2	9	2 1/4	5/8	5/8	6 7/8	7/8	3
16	3	H16303- *	8 1/2	10 3/8	2 1/4	5/8	5/8	8	1	3
18	3	H18303- *	9 1/2	11 7/8	2 1/2	5/8	5/8	9	1 1/4	3
	3 7/16	H18303716- *	9 1/2	11 7/8	3	3/4	5/8	9	1 1/4	4
20	3	H20303- *	10 1/2	13 1/4	2 1/2	5/8	5/8	10 1/4	1 1/4	3
	3 7/16	H20303716- *	10 1/2	13 1/4	3	3/4	5/8	10 1/4	1 1/4	4
24	3 7/16	H24303716- *	12 1/2	16 1/4	3	3/4	3/4	12 3/4	1 1/4	4

* See P. 37 for complete part no. information
 ▲ Hanger Frame Assembly can be furnished in stainless steel. Specify type

HANGER POCKETS

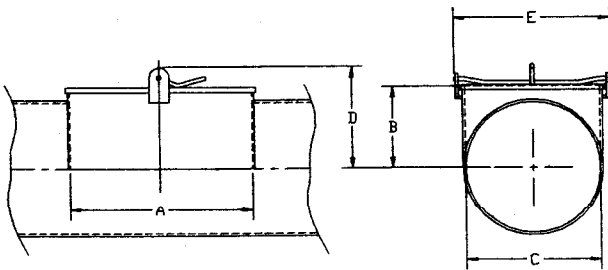

CONVEYOR DIAMETER	PART NUMBER	A **	B	C	D	E
4	HP4***	12	3 3/4	5	5 1/2	7 1/2
6	HP6***	12	4 3/4	7	6 1/2	9 1/2
9	HP9***	12	6 3/8	10	8 1/4	12 1/2
10	HP10***	12	6 5/8	11	8 1/2	13 1/2
12	HP12***	18	8	13	9 3/4	15 1/2
14	HP14***	18	9 1/2	15	11 1/4	17 1/2
16	HP16***	18	10 7/8	17	12 3/4	19 1/2
18	HP18***	18	12 3/8	19	14 1/4	21 1/2
20	HP20***	18	13 3/4	21	15 1/2	23 1/2
24	HP24***	18	16 3/4	25	18 1/2	27 1/2

*** Thickness of tubular trough
 ** Add 6" to "A" dimension for 3 or 4-bolt drilling

Bolt-on cover is available upon request.

HANGER BEARINGS

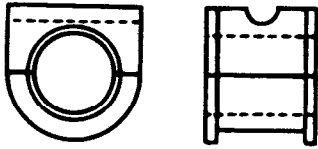
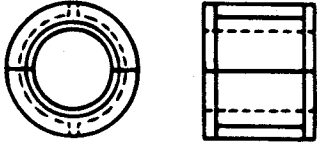
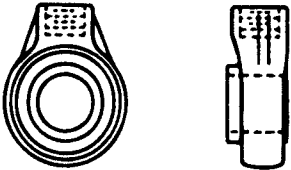

Hanger type	Bearing	Bore	Part Number	Weight
216 230 316		1	B 161-*	.50
		1-1/2	B 16112-*	1.6
		2	B 162-*	2.7
		2-7/16	B 162716-*	6.2
		3	B 163-*	8.0
		3-7/16	B 163716-*	13.7
		3-15/16	B 1631516-*	17.25
		4-7/16	B 164716-*	21.0
4-15/16	B 1641516-*	31.0		
220 226 326 30		1	BX 1-*	.50
		1-1/2	BX 112-*	1.0
		2	BX 2-*	2.0
		2-7/16	BX 2716-*	4.0
		3	BX 3-*	5.0
		3-7/16	BX 3716-*	9.0
		3-15/16	BX 31516-*	14.0
		4-7/16	BX 4716-*	17.0
4-15/16	BX 41516-*	20.0		
60 70 BALL BEARING **		1-1/2	SCHB112	3.5
		2	SCHB2	5.6
		2-7/16	SCHB2716	9.0
		3	SCHB3	18.0
		3-7/16	SCHB3716	24.0

DESIGNATION

- *-B BABBITT **
- BR BRONZE **
- H HARD IRON
- N NYLATRON
- W WOOD
- S STELLITE
- G GATKE GRAPHITE

Style #216, 230 and 316 are available only in Babbitt, Bronze, Gatke, Hard Iron, Stellite, UHMW and Wood at this time.

** Oil pipes and grease fittings are required for Babbitt, Ball, and Bronze Bearings, but can be supplied in others upon request.

Other Bearing materials are available - consult factory.

TROUGH ENDS

OUTSIDE LESS FEET

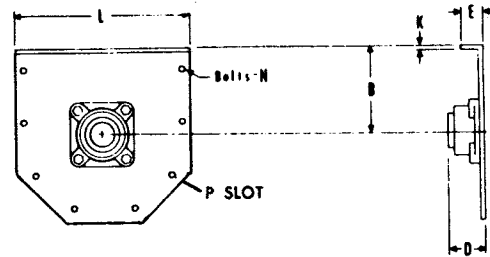
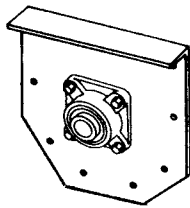

Conv Dia	Shaft Dia	▲ Part No.	B	D			E	K	L	N	Wt.**	P Slot
				Friction Bearing	Ball Bearing	Roller Bearing						
4	1	TE 41-*	3-5/8	2-3/16	1-5/8	—	1-7/16	3/16	7-3/4	3/8	5	7/16 x 9/16
6	1-1/2	TE 6112-*	4-1/2	3-3/16	2-3/16	3-11/16	1-1/2	3/16	9-3/4	3/8	10	7/16 x 9/16
9	1-1/2 2	TE 9112-*	6-1/8	3-1/4	2-3/16	3-11/16	1-5/8	1/4	13-3/4	3/8	15	7/16 x 9/16
		TE 92-*	6-1/8	4-1/4	2-1/2	3-13/16	1-5/8	1/4	13-3/4	3/8	18	
10	1-1/2 2	TE 10112-*	6-3/8	3-1/4	2-3/16	3-11/16	1-3/4	1/4	14-3/4	3/8	16	7/16 x 9/16
		TE 102-*	6-3/8	4-1/4	2-1/2	3-13/16	1-3/4	1/4	14-3/4	3/8	20	
12	2 2-7/16 3	TE 122-*	7-3/4	4-1/4	2-9/16	3-7/8	2	1/4	17-1/4	1/2	29	9/16 x 3/4
		TE 122716-*	7-3/4	5-1/4	2-15/16	4-7/16	2	1/4	17-1/4	1/2	31	
		TE 123-*	7-3/4	6-1/4	3-3/4	4-15/16	2	1/4	17-1/4	1/2	43	
14	2-7/16 3	TE 142716-*	9-1/4	5-5/16	2-15/16	4-7/16	2	5/16	19-1/4	1/2	36	9/16 x 3/4
		TE 143-*	9-1/4	5-5/16	3-3/4	4-15/16	2	5/16	19-1/4	1/2	48	
16	3	TE 163-*	10-5/8	6-5/16	3-13/16	5	2-1/2	5/16	21-1/4	5/8	62	11/16 x 7/8
18	3 3-7/16	TE 183-*	12-1/8	6-3/8	3-13/16	5	2-1/2	3/8	24-1/4	5/8	74	11/16 x 7/8
		TE 183716-*	12-1/8	7-3/8	4-5/16	5-9/16	2-1/2	3/8	24-1/4	5/8	85	
20	3 3-7/16	TE 203	13-1/2	6-3/8	3-7/8	5-1/16	2-1/2	3/8	26-1/4	5/8	112	11/16 x 7/8
		TE 203716-*	13-1/2	7-3/8	4-3/8	5-5/8	2-1/2	3/8	26-1/4	5/8	124	
24	3-7/16	TE 243716-*	16-1/2	7-3/8	4-3/8	5-5/8	2-1/2	3/8	30-1/4	5/8	156	11/16 x 7/8

OUTSIDE WITH FEET

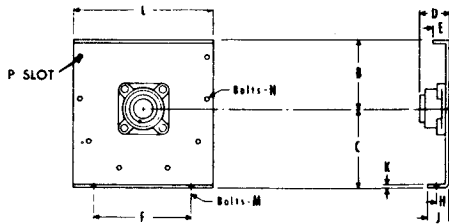
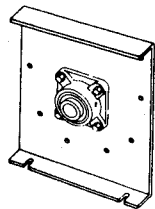

Conv Dia	Shaft Dia	▲ Part No.	B	C	D			E	F	H	J	K	L	M	N	Wt.**	P Slot
					Friction Bearing	Ball Bearing	Roller Bearing										
4	1	TEF 41-*	3-5/8	4-5/8	2-15/16	1-5/8	—	1-7/16	5-3/4	1	1-5/8	3/16	7-3/4	3/8	3/8	7	7/16 x 9/16
6	1-1/2	TEF 6112-*	4-1/2	5-5/8	3-15/16	2-3/16	3-11/16	1-1/2	8-1/8	1	1-3/4	3/16	9-3/4	3/8	3/8	12	7/16 x 9/16
9	1-1/2 2	TEF 9112-*	6-1/8	7-7/8	3-15/16	2-3/16	3-11/16	1-5/8	9-3/8	1-1/2	2-5/8	1/4	13-3/4	1/2	3/8	18	7/16 x 9/16
		TEF 92-*	6-1/8	7-7/8	4-15/16	2-1/2	3-13/16	1-5/8	9-3/8	1-1/2	2-5/8	1/4	13-3/4	1/2	3/8	22	
10	1-1/2 2	TEF 10112-*	6-3/8	8-7/8	3-15/16	2-3/16	3-11/16	1-3/4	9-1/2	1-3/4	2-7/8	1/4	14-3/4	1/2	3/8	20	7/16 x 9/16
		TEF 102-*	6-3/8	8-7/8	4-15/16	2-1/2	3-13/16	1-3/4	9-1/2	1-3/4	2-7/8	1/4	14-3/4	1/2	3/8	24	
12	2 2-7/16 3	TEF 122-*	7-3/4	9-5/8	5	2-9/16	3-7/8	2	12-1/4	1-5/8	2-3/4	1/4	17-1/4	5/8	1/2	36	9/16 x 3/4
		TEF 122716-*	7-3/4	9-5/8	5-1/2	2-15/16	4-7/16	2	12-1/4	1-5/8	2-3/4	1/4	17-1/4	5/8	1/2	38	
		TEF 123-*	7-3/4	9-5/8	5-5/8	3-3/4	4-15/16	2	12-1/4	1-5/8	2-3/4	1/4	17-1/4	5/8	1/2	50	
14	2-7/16 3	TEF 142716-*	9-1/4	10-7/8	5-1/2	2-15/16	4-7/16	2	13-1/2	1-5/8	2-7/8	5/16	19-1/4	5/8	1/2	45	9/16 x 3/4
		TEF 143-*	9-1/4	10-7/8	5-5/8	3-3/4	4-15/16	2	13-1/2	1-5/8	2-7/8	5/16	19-1/4	5/8	1/2	57	
16	3	TEF 163-*	10-5/8	12	5-11/16	3-13/16	5	2-1/2	14-7/8	2	3-1/4	5/16	21-1/4	5/8	5/8	75	11/16 x 7/8
18	3 3-7/16	TEF 183-*	12-1/8	13-3/8	5-11/16	3-13/16	5	2-1/2	16	2	3-1/4	3/8	24-1/4	5/8	5/8	89	11/16 x 7/8
		TEF 183716-*	12-1/8	13-3/8	6-15/16	4-5/16	5-9/16	2-1/2	16	2	3-1/4	3/8	24-1/4	5/8	5/8	101	
20	3 3-7/16	TEF 203-*	13-1/2	15	5-3/4	3-7/8	5-1/16	2-1/2	19-1/4	2-1/4	3-3/4	3/8	26-1/4	3/4	5/8	142	11/16 x 7/8
		TEF 203716-*	13-1/2	15	7	4-3/8	5-5/8	2-1/2	19-1/4	2-1/4	3-3/4	3/8	26-1/4	3/4	5/8	153	
24	3-7/16	TEF 243716-*	16-1/2	18-1/8	7	4-3/8	5-5/8	2-1/2	20	2-1/2	4-1/8	3/8	30-1/4	3/4	5/8	197	11/16 x 7/8

▲ Can be furnished with SP, SW, or SS Seals, See P. 49.
Trough End Plate can be in Stainless Steel. Specific Type

** Weights include ball bearing units.
*B Babbitt Brg.
*BB Ball Brg.

*RB Roller Bearing
*P Less Bearing

PEDESTAL TROUGH ENDS

SINGLE BEARING

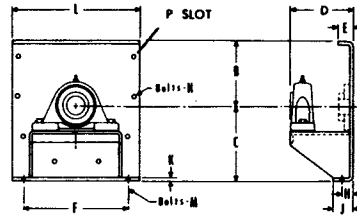
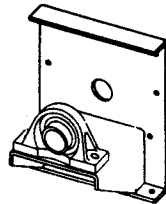

Conv Dia	Shaft Dia	▲ Part No.	B	C	D	E	F	H	J	K	L	M	N	P Slot	Wt.**
6	1-1/2	TEO 6112-*	4-1/2	5-5/8	6-3/16	1-1/2	8-1/8	1	1-3/4	3/16	9-3/4	3/8	3/8	7/16 x 9/16	19
9	1-1/2	TEO 9112-*	6-1/8	7-7/8	6-3/16	1-5/8	9-3/8	1-1/2	2-5/8	1/4	13-3/4	1/2	3/8	7/16 x 9/16	27
		TEO 92-*	6-1/8	7-7/8	7-1/2	1-5/8	9-3/8	1-1/2	2-5/8	1/4	13-3/4	1/2	3/8		36
10	1-1/2	TEO 10112-*	6-3/8	8-7/8	6-3/16	1-3/4	9-1/2	1-3/4	2-7/8	1/4	14-3/4	1/2	3/8	7/16 x 9/16	30
		TEO 102-*	6-3/8	8-7/8	7-1/2	1-3/4	9-1/2	1-3/4	2-7/8	1/4	14-3/4	1/2	3/8		37
12	2	TEO 122-*	7-3/4	9-5/8	7-1/2	2	12-1/4	1-5/8	2-3/4	1/4	17-1/4	5/8	1/2	9/16 x 3/4	56
	2-7/16	TEO 122716-*	7-3/4	9-5/8	8-3/4	2	12-1/4	1-5/8	2-3/4	1/4	17-1/4	5/8	1/2		59
	3	TEO 123-*	7-3/4	9-5/8	9-3/4	2	12-1/4	1-5/8	2-3/4	1/4	17-1/4	5/8	1/2		79
14	2-7/16	TEO 142716-*	9-1/4	10-7/8	8-3/4	2	13-1/2	1-5/8	2-7/8	5/16	19-1/4	5/8	1/2	9/16 x 3/4	68
		TEO 143-*	9-1/4	10-7/8	9-3/4	2	13-1/2	1-5/8	2-7/8	5/16	19-1/4	5/8	1/2		89
16	3	TEO 163-*	10-5/8	12	9-3/4	2-1/2	14-7/8	2	3-1/4	5/16	21-1/4	5/8	5/8	11/16 x 7/8	115
18	3	TEO 183-*	12-1/8	13-3/8	9-3/4	2-1/2	16	2	3-1/4	3/8	24-1/4	5/8	5/8	11/16 x 7/8	133
		TEO 183716-*	12-1/8	13-3/8	11-1/2	2-1/2	16	2	3-1/4	3/8	24-1/4	5/8	5/8		145
20	3	TEO 203-*	13-1/2	15	9-3/4	2-1/2	19-1/4	2-1/4	3-3/4	3/8	26-1/4	3/4	5/8	11/16 x 7/8	205
		TEO 203716-*	13-1/2	15	11-1/2	2-1/2	19-1/4	2-1/4	3-3/4	3/8	26-1/4	3/4	5/8		220
24	3-7/16	TEO 243716-*	16-1/2	18-1/8	11-1/2	2-1/2	20	2-1/2	4-1/8	3/8	30-1/4	3/4	5/8	11/16 x 7/8	274

DOUBLE BEARING

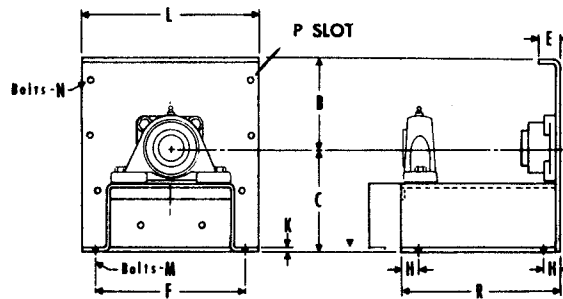
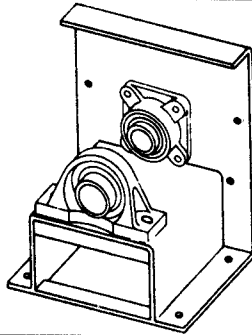

Conv Dia	Shaft Dia	▲▲ Part No.	B	C	E	F	H	K	L	M	N	R	P Slot	Wt.**
6	1-1/2	TED 6112-*	4-1/2	5-5/8	1-1/2	8-1/8	1	3/16	9-3/4	3/8	3/8	11	7/16 x 9/16	30
9	1-1/2	TED 9112-*	6-1/8	7-7/8	1-5/8	9-3/8	1-1/2	1/4	13-3/4	1/2	3/8	11	7/16 x 9/16	41
		TED 92-*	6-1/8	7-7/8	1-5/8	9-3/8	1-1/2	1/4	13-3/4	1/2	3/8	16		59
10	1-1/2	TED 10112-*	6-3/8	8-7/8	1-3/4	9-1/2	1-3/4	1/4	14-3/4	1/2	3/8	11	7/16 x 9/16	45
		TED 102-*	6-3/8	8-7/8	1-3/4	9-1/2	1-3/4	1/4	14-3/4	1/2	3/8	16		63
12	2	TED 122-*	7-3/4	9-5/8	2	12-1/4	1-5/8	1/4	17-1/4	5/8	1/2	16	9/16 x 3/4	88
	2-7/16	TED 122716-*	7-3/4	9-5/8	2	12-1/4	1-5/8	1/4	17-1/4	5/8	1/2	18-1/2		96
	3	TED 123-*	7-3/4	9-5/8	2	12-1/4	1-5/8	1/4	17-1/4	5/8	1/2	22		134
14	2-7/16	TED 142716-*	9-1/4	10-7/8	2	13-1/2	1-5/8	5/16	19-1/4	5/8	1/2	18-1/2	9/16 x 3/4	108
		TED 143-*	9-1/4	10-7/8	2	13-1/2	1-5/8	5/16	19-1/4	5/8	1/2	22		147
16	3	TED 163-*	10-5/8	12	2-1/2	14-7/8	2	5/16	21-1/4	5/8	5/8	22	11/16 x 7/8	186
18	3	TED 183-*	12-1/8	13-3/8	2-1/2	16	2	3/8	24-1/4	5/8	5/8	22	11/16 x 7/8	211
		TED 183716-*	12-1/8	13-3/8	2-1/2	16	2	3/8	24-1/4	5/8	5/8	25		241
20	3	TED 203-*	13-1/2	15	2-1/2	19-1/4	2-1/4	3/8	26-1/4	3/4	5/8	22	11/16 x 7/8	315
		TED 203716-*	13-1/2	15	2-1/2	19-1/4	2-1/4	3/8	26-1/4	3/4	5/8	25		351
24	3-7/16	TED 243716-*	16-1/2	18-1/8	2-1/2	20	2-1/2	3/8	30-1/4	3/4	5/8	25	11/16 x 7/8	422

- ▲ Can be furnished with SP, SS, or SW Seals, See P. 49. Trough End Plate can be in Stainless Steel. Specific Type.
- ▲▲ Can be furnished with SP, SS, SW, or SG Seals, in place of Flange Bearing See P. 49. Trough End Plate can be in Stainless Steel. Specific Type.

- ** Weights include ball bearing units.
- *B Babbitt Brg.
- *BB Ball Brg.
- *RB Roller Bearing
- *P Less Bearing

TROUGH ENDS

INSIDE

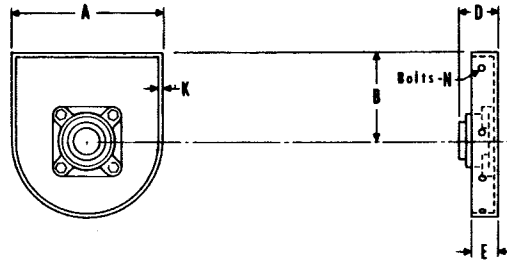
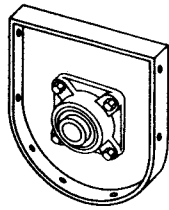

Conv Dia	Shaft Diameter	▲ Part No.	A	B	D			E	K	N	Wt.**
					Friction Bearing	Ball Bearing	Roller Bearing				
4	1	TEI 41-*	5	3-5/8	2-3/16	1-5/8	—	2	3/16	1/4	5
6	1-1/2	TEI 6112-*	7	4-1/2	3-3/16	2-3/16	3-11/16	2	3/16	5/16	11
9	1-1/2 2	TEI 9112-*	10	6-1/8	3-1/4	2-3/16	3-11/16	2	1/4	3/8	14
		TEI 92-*	10	6-1/8	4-1/4	2-1/2	3-13/16	2	1/4	3/8	18
10	1-1/2 2	TEI 10112-*	11	6-3/8	3-1/4	2-3/16	3-11/16	2	1/4	3/8	15
		TEI 102-*	11	6-3/8	4-1/4	2-1/2	3-13/16	2	1/4	3/8	19
12	2 2-7/16 3	TEI 122-*	13	7-3/4	4-1/4	2-9/16	3-7/8	2	1/4	1/2	27
		TEI 122716-*	13	7-3/4	5-1/4	2-15/16	4-7/16	2	1/4	1/2	29
		TEI 123-*	13	7-3/4	6-1/4	3-3/4	4-15/16	2	1/4	1/2	41
14	2-7/16 3	TEI 142716-*	15	9-1/4	5-5/16	2-15/16	4-7/16	2	5/16	1/2	35
		TEI 143-*	15	9-1/4	6-5/16	3-3/4	4-15/16	2	5/16	1/2	47
16	3	TEI 163-*	17	10-5/8	6-5/16	3-13/16	5	2	5/16	5/8	59
18	3 3-7/16	TEI 183-*	19	12-1/8	6-3/8	3-13/16	5	2	3/8	5/8	68
		TEI 183716-*	19	12-1/8	7-3/8	4-5/16	5-9/16	2	3/8	5/8	80
20	3 3-7/16	TEI 203-*	21	13-1/2	6-3/8	3-7/8	5-1/16	2	3/8	5/8	103
		TEI 203716-*	21	13-1/2	7-3/8	4-3/8	5-5/8	2	3/8	5/8	115
24	3-7/16	TEI 243716-*	25	16-1/2	7-3/8	4-3/8	5-5/8	2	3/8	5/8	145

INSIDE RECTANGULAR

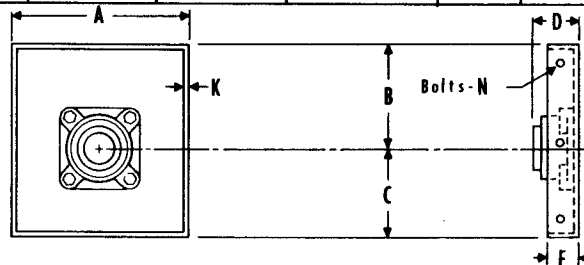
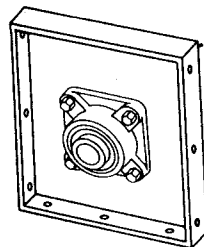

Conv Dia	Shaft Diameter	▲ Part No.	A	B	C	D			E	K	N	Wt.**
						Friction Bearing	Ball Bearing	Roller Bearing				
4	1	TEIR 41-*	5	3-5/8	2-1/2	2-3/16	1-5/8	—	2	3/16	1/4	6
6	1-1/2	TEIR 6112-*	7	4-1/2	3-1/2	3-3/16	2-3/16	3-11/16	2	3/16	5/16	11
9	1-1/2 2	TEIR 9112-*	10	6-1/8	5	3-1/4	2-3/16	3-11/16	2	1/4	3/8	15
		TEIR 92-*	10	6-1/8	5	4-1/4	2-1/2	3-13/16	2	1/4	3/8	19
10	1-1/2 2	TEIR 10112-*	11	6-3/8	5-1/2	3-1/4	2-3/16	3-11/16	2	1/4	3/8	17
		TEIR 102-*	11	6-3/8	5-1/2	4-1/4	2-1/2	3-13/16	2	1/4	3/8	21
12	2 2-7/16 3	TEIR 122-*	13	7-3/4	6-1/2	4-1/4	2-9/16	3-7/8	2	1/4	1/2	30
		TEIR 122716-*	13	7-3/4	6-1/2	5-1/4	2-15/16	4-7/16	2	1/4	1/2	32
		TEIR 123-*	13	7-3/4	6-1/2	6-1/4	3-3/4	4-15/16	2	1/4	1/2	43
14	2-7/16 3	TEIR 142716-*	15	9-1/4	7-1/2	5-5/16	2-15/16	4-7/16	2	5/16	1/2	37
		TEIR 143-*	15	9-1/4	7-1/2	6-5/16	3-3/4	4-15/16	2	5/16	1/2	49
16	3	TEIR 163-*	17	10-5/8	8-1/2	6-5/16	3-13/16	5	2	5/16	5/8	64
18	3 3-7/16	TEIR 183-*	19	12-1/8	9-1/2	6-3/8	3-13/16	5	2	3/8	5/8	73
		TEIR 183716-*	19	12-1/8	9-1/2	7-3/8	4-5/16	5-9/16	2	3/8	5/8	84
20	3 3-7/16	TEIR 203-*	21	13-1/2	10-1/2	6-3/8	3-7/8	5-1/16	2	3/8	5/8	112
		TEIR 203716-*	21	13-1/2	10-1/2	7-3/8	4-3/8	5-5/8	2	3/8	5/8	123
24	3-7/16	TEIR 243716-*	25	16-1/2	12-1/2	7-3/8	4-3/8	5-5/8	2	3/8	5/8	157

▲ Can be furnished with SP, SS, or SW Seals, See P. 49.
Trough End Plate can be in Stainless Steel. Specific Type.

** Weights include ball bearing units.
-B Babbitt Brg.
-BB Ball Brg.

-*RB Roller Bearing
-*P Less Bearing

TROUGH ENDS



FLARED

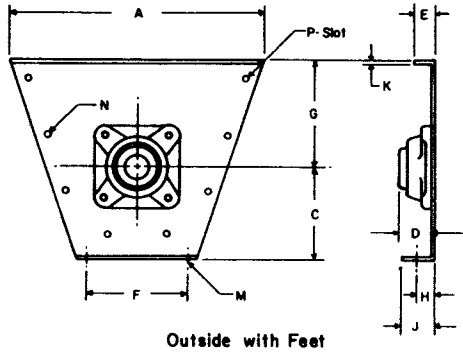

Outside with Feet

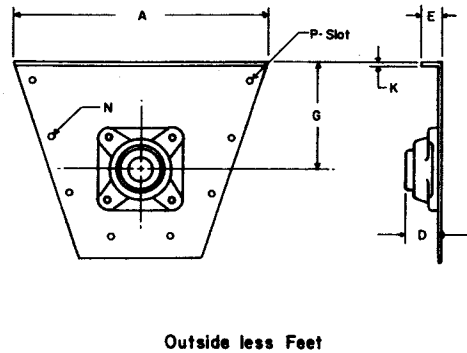

Outside less Feet

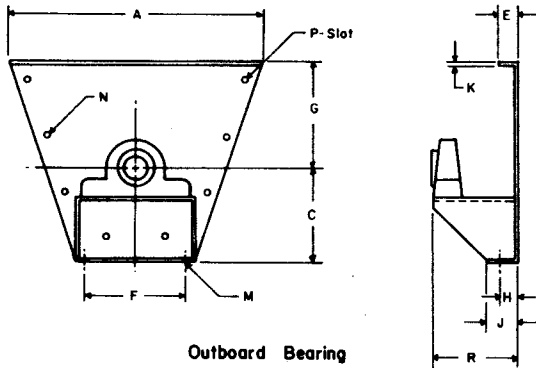

Outboard Bearing

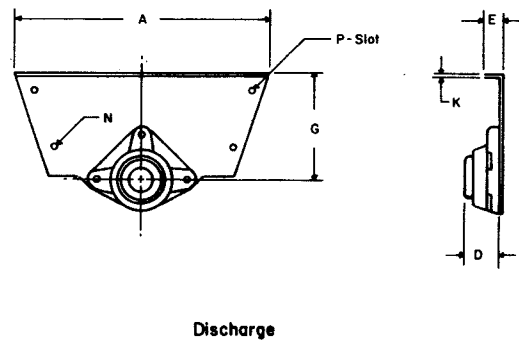

Discharge

RECTANGULAR

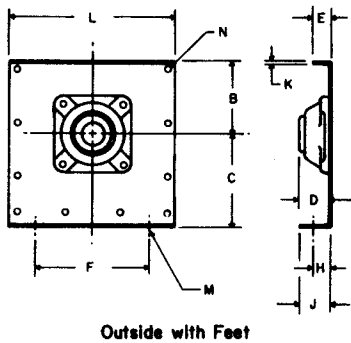

Outside with Feet

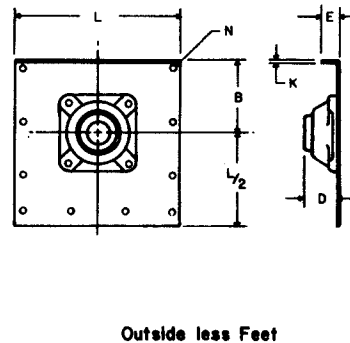

Outside less Feet

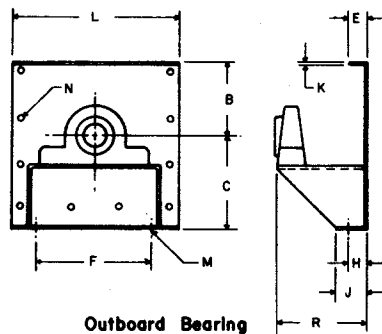

Outboard Bearing

NOTE: FOR DIMENSIONS & PART NUMBERS SEE FOLLOWING PAGE.

TROUGH ENDS



PART NUMBERS

Conv Dia	Shaft Dia.	PART NUMBER FLARED								PART NUMBER RECTANGULAR					
		▲ Outside With Ft.	Wt	▲ Outside Less Ft.	Wt	● Outb'd. Brg.	Wt	Discharge	Wt	▲ Outside With Ft.	Wt	▲ Outside Less Ft.	Wt	● Outb'd. Brg	Wt
4	1	—	—	—	—	—	—	—	—	TEFR41 .*	8	TER41.*	6	TEOR41 .*	16
6	1-1/2	TEF6112F.*	15	TE6112F.*	13	TEO6112F.*	22	TEOD6112F.**	11	TEFR6112 .*	13	TER6112.*	11	TEOR6112 .*	20
9	1-1/2 2	TEF9112F.*	22	TE9112F.*	19	TEO9112F.*	31	TEOD9112F.**	15	TEFR9112 .*	19	TER9112.*	16	TEOR9112.*	28
		TEF92F.*	27	TE92F.*	24	TEO92F.*	36	TEOD92F.**	20	TEFR92 .*	24	TER92.*	21	TEOR92 .*	33
10	1-1/2 2	—	—	—	—	—	—	—	—	TEFR10112 .*	28	TER10112.*	23	TEOR10112.*	38
		—	—	—	—	—	—	—	—	TEFR102 .*	32	TER102.*	27	TEOR102 .*	52
12	2 2-7/16 3	TEF122F.*	42	TE122F.*	36	TEO122F.*	63	TEOD122F.**	28	TEFR122 .*	39	TER122.*	32	TEOR122 .*	49
		TEF122716F.*	44	TE122716F.*	37	TEO122716F.*	64	TEOD122716F.**	29	TEFR122716 .*	40	TER122716.*	33	TEOR122716.*	60
		TEF123F.*	56	TE123F.*	49	TEO123F.*	76	TEOD123F.**	41	TEFR123 .*	58	TER123.*	51	TEOR123 .*	72
14	2-7/16 3	TEF142716F.*	52	TE142716F.*	43	TEO142716F.*	75	TEOD142716F.**	33	TEFR142716 .*	48	TER142716.*	39	TEOR142716 .*	71
		TEF143F.*	64	TE143F.*	55	TEO143F.*	87	TEOD143F.**	45	TEFR143 .*	66	TER143.*	57	TEOR143 .*	89
16	3	TEF163F.*	85	TE163F.*	72	TEO163F.*	125	TEOD163F.**	56	TEFR163 .*	85	TER163.*	72	TEOR163 .*	125
18	3 3-7/16	TEF183F.*	98	TE183F.*	83	TEO183F.*	138	TEOD183F.**	63	TEFR183 .*	94	TER183.*	79	TEOR183 .*	134
		TEF183716F.*	104	TE183716F.*	89	TEO183716F.*	144	TEOD183716F.**	69	TEFR183716 .*	101	TER183716.*	86	TEOR183716 .*	141
20	3 3-7/16	TEF203F.*	133	TE203F.*	103	TEO203F.*	196	TEOD203F.**	75	TEFR203 .*	134	TER203.*	104	TEOR203 .*	197
		TEF203716F.*	139	TE203716F.*	109	TEO203716F.*	202	TEOD203716F.**	81	TEFR203716 .*	140	TER203716.*	110	TEOR203716 .*	203
24	3-7/16	TEF243716F.*	179	TE243716F.*	132	TEO243716F.*	250	TEOD243716F.**	96	TEFR243716 .*	179	TER243716.*	138	TEOR243716 .*	256

DIMENSIONS

Conv Dia	Shaft Dia.	A	B	C	D			E	F	G	H	J	K	L	M	N	R	P Slot
					Friction Brg.	Ball Brg.	Roller Brg.											
4	1	—	3-5/8	4-5/8	3	1-5/8	—	1-1/2	5-3/4	—	1	1-5/8	3/16	7-3/4	3/8	3/8	—	7/16 x 9/16
6	1-1/2	16-5/8	4-1/2	5-5/8	4	2-3/16	3-3/4	1-1/2	8-1/8	7	1	1-3/4	3/16	9-3/4	3/8	3/8	6-3/16	7/16 x 9/16
9	1-1/2 2	21-1/4	6-1/8	7-7/8	4	2-3/16	3-3/4	1-5/8	9-3/8	9	1-1/2	2-5/8	1/4	13-3/4	1/2	3/8	6-3/16	7/16 x 9/16
					5	2-1/2	3-7/8										7-1/2	
10	1-1/2 2	—	6-3/8	8-7/8	4	2-3/16	3-3/4	1-3/4	9-1/2	—	1-3/4	2-7/8	1/4	14-3/4	1/2	3/8	6-3/16	7/16 x 9/16
					5	2-1/2	3-7/8										7-1/2	
12	2 2-7/16 3	26-3/8	7-3/4	9-5/8	5	2-9/16	3-7/8	2	12-1/4	10	1-5/8	2-3/4	1/4	17-1/4	5/8	1/2	7-1/2	9/16 x 3/4
					5-1/2	2-15/16	4-1/2										8-3/4	
					5-5/8	3-3/4	5										9-3/4	
14	2-7/16 3	28-3/8	9-1/4	10-7/8	5-1/2	2-15/16	4-1/2	2	13-1/2	11	1-5/8	2-7/8	5/16	19-1/4	5/8	1/2	8-3/4	9/16 x 3/4
					5-5/8	3-3/4	5										9-3/4	
16	3	32-1/2	10-5/8	12	5-3/4	3-13/16	5	2-1/2	14-7/8	11-1/2	2	3-1/4	5/16	21-1/4	5/8	5/8	9-3/4	11/16 x 7/8
18	3 3-7/16	36-1/2	12-1/8	13-3/8	5-3/4	3-13/16	5	2-1/2	16	12-1/8	2	3-1/4	3/8	24-1/4	5/8	5/8	9-3/4	11/16 x 7/8
					7	4-5/16	5-5/8										11-1/2	
20	3 3-7/16	39-1/2	13-1/2	15	5-3/4	3-7/8	5	2-1/2	19-1/4	13-1/2	2-1/4	3-3/4	3/8	26-1/4	3/4	5/8	9-3/4	11/16 x 7/8
					7	4-3/8	5-5/8										11-1/2	
24	3-7/16	45-1/2	16-1/2	18-1/8	7	4-3/8	5-5/8	2-1/2	20	16-1/2	2-1/2	4-1/8	3/8	30-1/4	3/4	5/8	11-1/2	11/16 x 7/8

- *B Babbitt Brg.
- *BB Ball Brg.
- *RB Roller Bearing
- *P Less Bearing
- **B Babbitt Brg.
- **BB Ball Brg.
- **P Less Bearing

Trough End Plate can be in Stainless Steel. Specific Type.
 ▲ Can be furnished with SP, SS, or SW Seals see Pg. 49 and 50.
 ● Can be furnished with SP, SS, SW, or SG Seals see Pg. 49 and 50.

TUBULAR HOUSING ENDS

OUTSIDE

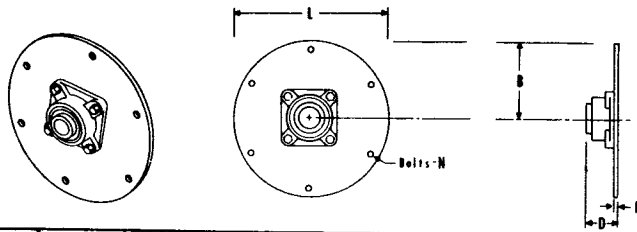

Conv. Dia.	Shaft Dia.	Part No.	B	D			K	L	N	Wt. ▲
				Friction Bearing	Ball Bearing	Roller Bearing				
4	1	TTE 41-*	3-7/8	2-3/16	1-5/8	—	3/16	7-3/4	3/8	4
6	1-1/2	TTE6112-*	4-7/8	3-3/16	2-3/16	3-11/16	3/16	9-3/4	3/8	5
9	1-1/2	TTE 9112-*	6-7/8	3-1/4	2-3/16	3-11/16	1/4	13-3/4	3/8	12
	2	TTE 92-*	6-7/8	4-1/4	2-1/2	3-13/16	1/4	13-3/4	3/8	15
10	1-1/2	TTE 10112-*	7-3/8	3-1/4	2-3/16	3-11/16	1/4	14-3/4	3/8	13
	2	TTE 102-*	7-3/8	4-1/4	2-1/2	3-13/16	1/4	14-3/4	3/8	17
12	2	TTE 122-*	8-5/8	4-1/4	2-9/16	3-7/8	1/4	17-1/4	1/2	22
	2-7/16	TTE 122716-*	8-5/8	5-1/4	2-15/16	4-7/16	1/4	17-1/4	1/2	24
	3	TTE 123-*	8-5/8	6-1/4	3-3/4	4-15/16	1/4	17-1/4	1/2	36
14	2-7/16	TTE 142716-*	9-5/8	5-5/16	2-15/16	4-7/16	5/16	19-1/4	1/2	30
	3	TTE 143-*	9-5/8	6-5/16	3-3/4	4-15/16	5/16	19-1/4	1/2	42
16	3	TTE 163-*	10-5/8	6-5/16	3-13/16	5	5/16	21-1/4	5/8	52
	3	TTE 183-*	12-1/8	6-3/8	3-13/16	5	3/8	24-1/4	5/8	63
18	3-7/16	TTE 183716-*	12-1/8	7-3/8	4-5/16	5-9/16	3/8	24-1/4	5/8	74
	3	TTE 203-*	13-1/8	6-3/8	3-7/8	5-1/16	3/8	26-1/4	5/8	85
20	3-7/16	TTE203716-*	13-1/8	7-3/8	4-3/8	5-5/8	3/8	26-1/4	5/8	97
	3-7/16	TTE 243716-*	15-1/8	7-3/8	4-3/8	5-5/8	3/8	30-1/4	5/8	115

OUTSIDE WITH FEET

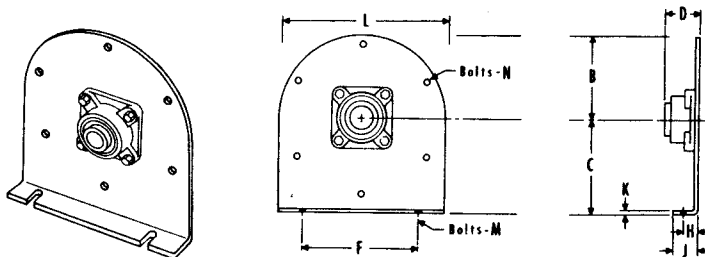

Conv. Dia.	Shaft Dia.	Part No.	B	C	D			F	H	J	K	L	M	N	Wt. ▲
					Friction Brg.	Ball Brg.	Roller Brg.								
4	1	TTEF41-*	3-7/8	4-5/8	2-3/16	1-5/8	5-3/4	1	1-5/8	3/16	7-3/4	3/8	3/8	5	
6	1-1/2	TTEF6112-*	4-7/8	5-5/8	3-3/16	2-3/16	3-11/16	8-1/8	1	1-3/4	3/16	9-3/4	3/8	3/8	11
9	1-1/2	TTEF9112-*	6-7/8	7-7/8	3-1/4	2-3/16	3-11/16	9-3/8	1-1/2	2-5/8	1/4	13-3/4	1/2	3/8	16
	2	TTEF92-*	6-7/8	7-7/8	4-1/4	2-1/2	3-13/16	9-3/8	1-1/2	2-5/8	1/4	13-3/4	1/2	3/8	19
10	1-1/2	TTEF10112-*	7-3/8	8-7/8	3-1/4	2-3/16	3-11/16	9-1/2	1-3/4	2-7/8	1/4	14-3/4	1/2	3/8	18
	2	TTEF102-*	7-3/8	8-7/8	4-1/4	2-1/2	3-13/16	9-1/2	1-3/4	2-7/8	1/4	14-3/4	1/2	3/8	22
12	2	TTEF122-*	8-5/8	9-5/8	4-1/4	2-9/16	3-7/8	12-1/4	1-5/8	2-3/4	1/4	17-1/4	5/8	1/2	32
	2-7/16	TTEF122716-*	8-5/8	9-5/8	5-1/4	2-15/16	4-7/16	12-1/4	1-5/8	2-3/4	1/4	17-1/4	5/8	1/2	34
	3	TTEF123-*	8-5/8	9-5/8	6-1/4	3-3/4	4-15/16	12-1/4	1-5/8	2-3/4	1/4	17-1/4	5/8	1/2	46
14	2-7/16	TTEF142716-*	9-5/8	10-7/8	5-5/16	2-15/16	4-7/16	13-1/2	1-5/8	2-7/8	5/16	19-1/4	5/8	1/2	39
	3	TTEF143-*	9-5/8	10-7/8	6-5/16	3-3/4	4-15/16	13-1/2	1-5/8	2-7/8	5/16	19-1/4	5/8	1/2	51
16	3	TTEF163-*	10-5/8	12	6-5/16	3-13/16	5	14-7/8	2	3-1/4	5/16	21-1/4	5/8	5/8	65
18	3	TTEF183-*	12-1/8	13-3/8	6-3/8	3-13/16	5	16	2	3-1/4	3/8	24-1/4	5/8	5/8	77
	3-7/16	TTEF183716-*	12-1/8	13-3/8	7-3/8	4-5/16	5-9/16	16	2	3-1/4	3/8	24-1/4	5/8	5/8	88
20	3	TTEF203-*	13-1/8	15	6-3/8	3-7/8	5-1/16	19-1/4	2-1/4	3-3/4	3/8	26-1/4	3/4	5/8	116
	3-7/16	TTEF203716-*	13-1/8	15	7-3/8	4-3/8	5-5/8	19-1/4	2-1/4	3-3/4	3/8	26-1/4	3/4	5/8	128
24	3-7/16	TTEF243716-*	15-1/8	18-1/8	7-3/8	4-3/8	5-5/8	20	2-1/2	4-1/8	3/8	30-1/4	3/4	5/8	162

▲ Weights include Ball Bearing Units.

*See Page 38 for Bearing Type and page 49 and 50 for seals.

TUBULAR HOUSING ENDS

OUTBOARD BEARING

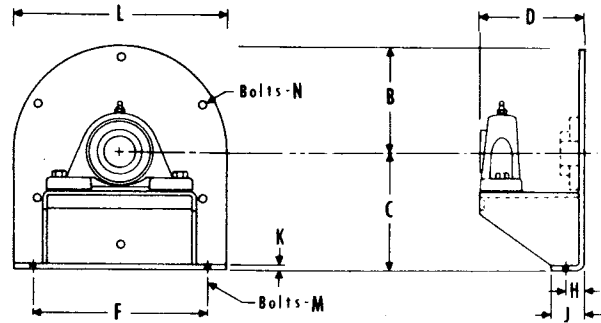
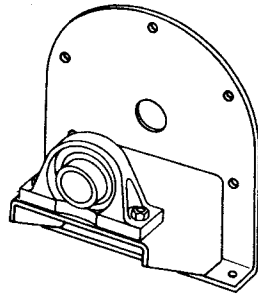

Conv Dia	Shaft Dia	Part Number	B	C	D	F	H	J	K	L	M	N	Wt.▲
6	1-1/2	TTEO6112-*	4-7/8	5-5/8	6-3/16	8-1/8	1	1-3/4	3/16	9-3/4	3/8	3/8	18
9	1-1/2	TTEO9112-*	6-7/8	7-7/8	6-3/16	9-3/8	1-1/2	2-5/8	1/4	13-3/4	1/2	3/8	25
	2	TTEO92-*	6-7/8	7-7/8	7-1/2	9-3/8	1-1/2	2-5/8	1/4	13-3/4	1/2	3/8	34
10	1-1/2	TTEO10112-*	7-3/8	8-7/8	6-3/16	9-1/2	1-3/4	2-7/8	1/4	14-3/4	1/2	3/8	42
	2	TTEO102-*	7-3/8	8-7/8	7-1/2	9-1/2	1-3/4	2-7/8	1/4	14-3/4	1/2	3/8	60
12	2	TTEO122-*	8-5/8	9-5/8	7-1/2	12-1/4	1-5/8	2-3/4	1/4	17-1/4	5/8	1/2	85
	2-7/16	TTEO122716-*	8-5/8	9-5/8	8-3/4	12-1/4	1-5/8	2-3/4	1/4	17-1/4	5/8	1/2	93
	3	TTEO123-*	8-5/8	9-5/8	9-3/4	12-1/4	1-5/8	2-3/4	1/4	17-1/4	5/8	1/2	131
14	2-7/16	TTEO142716-*	9-5/8	10-7/8	8-3/4	13-1/2	1-5/8	2-7/8	5/16	19-1/4	5/8	1/2	104
	3	TTEO143-*	9-5/8	10-7/8	9-3/4	13-1/2	1-5/8	2-7/8	5/16	19-1/4	5/8	1/2	143
16	3	TTEO163-*	10-5/8	12	9-3/4	14-7/8	2	3-1/4	5/16	21-1/4	5/8	5/8	178
18	3	TTEO183-*	12-1/8	13-3/8	9-3/4	16	2	3-1/4	3/8	24-1/4	5/8	5/8	200
	3-7/16	TTEO183716-*	12-1/8	13-3/8	11-1/2	16	2	3-1/4	3/8	24-1/4	5/8	5/8	230
20	3	TTEO203-*	13-1/8	15	9-3/4	19-1/4	2-1/4	3-3/4	3/8	26-1/4	3/4	5/8	300
	3-7/16	TTEO203716-*	13-1/8	15	11-1/2	19-1/4	2-1/4	3-3/4	3/8	26-1/4	3/4	5/8	335
24	3-7/16	TTEO243716-*	15-1/8	18-1/8	11-1/2	20	2-1/2	4-1/8	3/8	30-1/4	3/4	5/8	400

DOUBLE BEARING

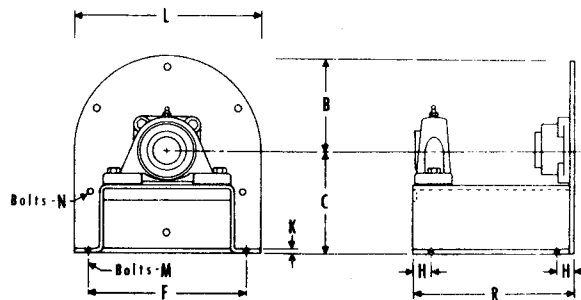
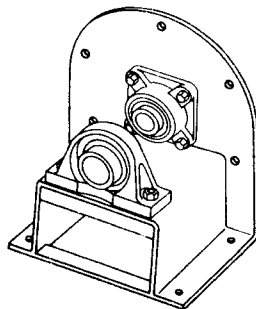

Conv Dia	Shaft Dia	Part Number	B	C	F	H	K	L	M	N	R	Wt.▲
6	1-1/2	TTED 6112-*	4-7/8	5-5/8	8-1/8	1	3/16	9-3/4	3/8	3/8	11	29
9	1-1/2	TTED 9112-*	6-7/8	7-7/8	9-3/8	1-1/2	1/4	13-3/4	1/2	3/8	11	41
	2	TTED 92-*	6-7/8	7-7/8	9-3/8	1-1/2	1/4	13-3/4	1/2	3/8	16	57
10	1-1/2	TTED 10112-*	7-3/8	8-7/8	9-1/2	1-3/4	1/4	14-3/4	1/2	3/8	11	27
	2	TTED 102-*	7-3/8	8-7/8	9-1/2	1-3/4	1/4	14-3/4	1/2	3/8	16	34
12	2	TTED 122-*	8-5/8	9-5/8	12-1/4	1-5/8	1/4	17-1/4	5/8	1/2	16	53
	2-7/16	TTED 122716-*	8-5/8	9-5/8	12-1/4	1-5/8	1/4	17-1/4	5/8	1/2	18-1/2	56
	3	TTED 123-*	8-5/8	9-5/8	12-1/4	1-5/8	1/4	17-1/4	5/8	1/2	22	76
14	2-7/16	TTED 142716-*	9-5/8	10-7/8	13-1/2	1-5/8	5/16	19-1/4	5/8	1/2	18-1/2	64
	3	TTED 143-*	9-5/8	10-7/8	13-1/2	1-5/8	5/16	19-1/4	5/8	1/2	22	85
16	3	TTED 163-*	10-5/8	12	14-7/8	2	5/16	21-1/4	5/8	5/8	22	107
18	3	TTED 183-*	12-1/8	13-3/8	16	2	3/8	24-1/4	5/8	5/8	22	122
	3-7/16	TTED183716-*	12-1/8	13-3/8	16	2	3/8	24-1/4	5/8	5/8	25	134
20	3	TTED 203-*	13-1/8	15	19-1/4	2-1/4	3/8	26-1/4	3/4	5/8	22	190
	3-7/16	TTED 203716-*	13-1/8	15	19-1/4	2-1/4	3/8	26-1/4	3/4	5/8	25	205
24	3-7/16	TTED 243716-*	15-1/8	18-1/8	20	2-1/2	3/8	30-1/4	3/4	5/8	25	251

▲ Weights include Ball Bearing Units.

*See Page 38 for Bearing Type and page 49 and 50 for seals.

TROUGH ENDS

OUTSIDE DISCHARGE

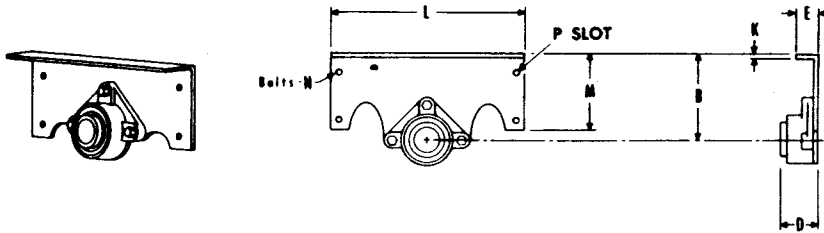

Conv Dia	Shaft Dia	Part Number	B	D			E	K	L	M	N	P Slot	Wt.**
				Friction Brg	Ball Brg	Roller Brg							
4	1	TEOD 41-*	3-5/8	2-3/16	1-5/8	—	2	3/16	8	3-5/8	3/8	7/16 x 9/16	4
6	1-1/2	TEOD 6112-*	4-1/2	3-3/16	2-3/16	3-11/16	2	3/16	9-3/4	4-1/2	3/8	7/16 x 9/16	8
9	1-1/2 2	TEOD 9112-*	6-1/8	3-1/4	2-3/16	3-11/16	2	1/4	13-3/4	6-1/8	3/8	7/16 x 9/16	11 14
		TEOD 92-*	6-1/8	4-1/4	2-1/2	3-13/16	2	1/4	13-3/4	6-1/8	3/8		
10	1-1/2 2	TEOD 10112-*	6-3/8	3-1/4	2-3/16	3-11/16	2	1/4	14-3/4	6-3/8	3/8	7/16 x 9/16	11 15
		TEOD 102-*	6-3/8	4-1/4	2-1/2	3-13/16	2	1/4	14-3/4	6-3/8	3/8		
12	2 2-7/16 3	TEOD 122-*	7-3/4	4-1/4	2-9/16	3-7/8	2	1/4	17-1/2	7-3/4	1/2	9/16 x 3/4	21 23 34
		TEOD 122716-*	7-3/4	5-1/4	2-15/16	4-7/16	2	1/4	17-1/2	7-3/4	1/2		
		TEOD 123-*	7-3/4	6-1/4	3-3/4	4-15/16	2	1/4	17-1/2	7-3/4	1/2		
14	2-7/16 3	TEOD 142716-*	9-1/4	5-5/16	2-15/16	4-7/16	2	5/16	19-1/4	9-1/4	1/2	9/16 x 3/4	26 38
		TEOD 143-*	9-1/4	6-5/16	3-3/4	4-15/16	2	5/16	19-1/4	9-1/4	1/2		
16	3	TEOD 163-*	10-5/8	6-5/16	3-13/16	5	2	5/16	21-1/8	10-5/8	5/8	11/16 x 7/8	47
18	3 3-7/16	TEOD 183-*	12-1/8	6-3/8	3-13/16	5	2	3/8	23-1/2	12-1/8	5/8	11/16 x 7/8	54 65
		TEOD 183716-*	12-1/8	7-3/8	4-5/16	5-9/16	2	3/8	23-1/2	12-1/8	5/8		
20	3 3-7/16	TEOD 203-*	13-1/2	6-3/8	3-7/8	5-1/16	2	3/8	26-3/4	13-1/2	5/8	11/16 x 7/8	77 89
		TEOD 203716-*	13-1/2	7-3/8	4-3/8	5-5/8	2	3/8	26-3/4	13-1/2	5/8		
24	3-7/16	TEOD 243716-*	16-1/2	7-3/8	4-3/8	5-5/8	2	3/8	30-1/2	16-1/2	5/8	11/16 x 7/8	109

INSIDE DISCHARGE

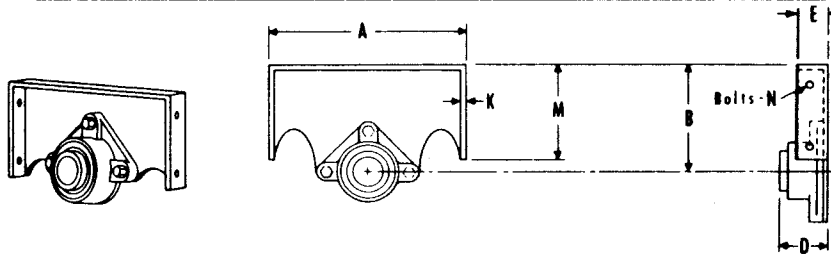

Conv Dia	Shaft Dia	Part Number	A	B	D			E	K	M	N	Wt.**
					Friction Brg	Ball Brg	Roller Brg					
4	1	TEID 41-*	5	3-5/8	2-3/16	1-5/8	—	2	3/16	3-5/8	3/8	4
6	1-1/2	TEID 6112-*	7	4-1/2	3-3/16	2-3/16	3-11/16	2	3/16	4-1/2	3/8	8
9	1-1/2 2	TEID 9112-*	10	6-1/8	3-1/4	2-3/16	3-11/16	2	1/4	6-1/8	3/8	11 14
		TEID 92-*	10	6-1/8	4-1/4	2-1/2	3-13/16	2	1/4	6-1/8	3/8	
10	1-1/2 2	TEID 10112-*	11	6-3/8	3-1/4	2-3/16	3-11/16	2	1/4	6-3/8	3/8	11 15
		TEID 102-*	11	6-3/8	4-1/4	2-1/2	3-13/16	2	1/4	6-3/8	3/8	
12	2 2-7/16 3	TEID 122-*	13	7-3/4	4-1/4	2-9/16	3-7/8	2	1/4	7-3/4	1/2	20 22 34
		TEID 122716-*	13	7-3/4	5-1/4	2-15/16	4-7/16	2	1/4	7-3/4	1/2	
		TEID 123-*	13	7-3/4	6-1/4	3-3/4	4-15/16	2	1/4	7-3/4	1/2	
14	2-7/16 3	TEID 142716-*	15	9-1/4	5-5/16	2-15/16	4-7/16	2	5/16	9-1/4	1/2	25 37
		TEID 143-*	15	9-1/4	6-5/16	3-3/4	4-15/16	2	5/16	9-1/4	1/2	
16	3	TEID 163-*	17	10-5/8	6-5/16	3-13/16	5	2	5/16	10-5/8	5/8	45
18	3 3-7/16	TEID 183-*	19	12-1/8	6-3/8	3-13/16	5	2	3/8	12-1/8	5/8	50 62
		TEID 183716-*	19	12-1/8	7-3/8	4-5/16	5-9/16	2	3/8	12-1/8	5/8	
20	3 3-7/16	TEID 203-*	21	13-1/2	6-3/8	3-7/8	5-1/16	2	3/8	13-1/2	5/8	72 83
		TEID 203716-*	21	13-1/2	7-3/8	4-3/8	5-5/8	2	3/8	13-1/2	5/8	
24	3-7/16	TEID 243716-*	25	16-1/2	7-3/8	4-3/8	5-5/8	2	3/8	16-1/2	5/8	103

▲ Trough End Plate Can be Furnished in Stainless Steel. Specify Type.
 ** Weights include ball bearing units.

-*B Babbitt Brg.
 -*BB Ball Brg.
 -*P Less Bearing

TROUGH END BEARINGS

Bore	Part Number	C	D	E	G	N
1	EB 1-B	2-3/4	3-3/4	2	5/8	3/8
1-1/2	EB 112-B	4	5-3/8	3	5/8	1/2
2	EB 2-B	5-1/8	6-1/2	4	5/8	5/8
2-7/16	EB 2716-B	5-5/8	7-3/8	5	5/8	5/8
3	EB 3-B	6	7-3/4	6	5/8	3/4
3-7/16	EB 3716-B	6-3/4	9-1/4	7	5/8	3/4

Bore	Part Number	C	D	E	G	N
1-1/2	EB 112-R	4-1/8	5-3/8	3-1/2	1-3/16	1/2
2	EB 2-R	4-3/8	5-5/8	3-5/8	1-3/16	1/2
2-7/16	EB 2716-R	5-3/8	6-7/8	4-3/16	1-1/2	5/8
3	EB 3-R	6	7-3/4	4-11/16	1-5/8	3/4
3-7/16	EB 3716-R	7	9-1/4	5-1/4	1-7/8	3/4

Bore	Part Number	C	D	E	G	N	Type
1	EB 1-BB	2-3/4	3-3/4	1-3/8	1/2	3/8	SC
1-1/2	EB 112-BB	4	5-1/8	1-7/8	9/16	1/2	SC
2	EB 2-BB	5-1/8	6-1/2	2-3/16	11/16	5/8	SCM
2-7/16	EB 2716-BB	5-5/8	7	2-5/16	11/16	5/8	SC
3	EB 3-BB	6	7-3/4	3-1/8	7/8	3/4	SCM
3-7/16	EB 3716-BB	6-3/4	8-7/16	3-3/8	1	3/4	SCM

Bore	Part Number	E	G	H	J	K	L	M	N
1	DEB 1-BB	1-3/8	1/2	3-7/8	5-3/8	1-15/16	2-11/16	2	3/8
1-1/2	DEB 112-BB	1-7/8	9/16	5-5/8	7-1/4	2-13/16	3-5/8	2-1/2	1/2
2	DEB 2-BB	2-3/16	5/8	6-1/4	8	3-1/8	4	3	1/2
2-7/16	DEB 2716-BB	2-5/16	11/16	8	9-7/8	4	4-13/16	3-1/2	5/8
3	DEB 3-BB	3-1/8	7/8	8-1/2	11	4-1/4	5-1/2	4	3/4
3-7/16	DEB 3716-BB	3-3/8	1	9-1/2	12	4-3/4	6	4-1/2	3/4

Bore	Part Number	E	G	H	J	K	L	M	N
1	DEB 1-B	2	5/8	3-7/8	5-3/8	1-15/16	2-11/16	1	3/8
1-1/2	DEB 112-B	3	5/8	5-5/8	7-1/4	2-13/16	3-5/8	1-1/4	1/2
2	DEB 2-B	4	5/8	6-1/4	8	3-1/8	4	1-5/8	5/8
2-7/16	DEB 2716-B	5	5/8	8	9-7/8	4	4-15/16	1-7/8	5/8
3	DEB 3-B	6	5/8	8-1/2	11	4-1/4	5-1/2	2-1/8	3/4
3-7/16	DEB 3716-B	7	5/8	9-1/2	12	4-3/4	6	2-1/2	3/4

Bore	Part Number	E	G	N	R	S	T	U	W
1-1/2	PB 112-R	3-3/8	1-1/4	1/2	6-1/4	7-7/8	2-3/8	4-1/4	2-1/8
2	PB 2-R	3-1/2	1-5/16	5/8	7	8-7/8	2-1/2	4-1/2	2-1/4
2-7/16	PB 2716-R	4	1-5/8	5/8	8-1/2	10-1/2	2-7/8	5-1/2	2-3/4
3	PB 3-R	4-1/2	1-7/8	3/4	9-1/2	12	3	6-1/4	3-1/8
3-7/16	PB 3716-R	5	2-1/4	7/8	11	14	3-1/2	7-1/2	3-3/4

BORE	PART NUMBER	E	G	N	R	S	T	U	W	X
1	PB1-BB	3/4	5/8	3/8	4 1/8	5 1/2	1 7/16	2 13/16	1 7/16	1 3/16
1 1/2	PB112-BB	1 1/8	15/16	1/2	5 1/2	7 1/4	1 15/16	4 3/16	2 1/8	1 11/16
2	PB2-BB	1 1/4	7/8	5/8	6 15/16	8 7/8	2 5/16	5	2 1/2	1 7/8
2 7/16	PB2716-BB	1 5/16	7/8	5/8	8	9 1/2	2 3/8	5 7/16	2 3/4	2
3	PB3-BB	1 1/2	1 1/4	7/8	9	11 3/4	3	7	3 1/2	2 3/8
3 7/16	PB3716-BB	1 9/16	1 5/16	7/8	11	14	3 3/8	8	4	2 1/2

babbitted flange unit*

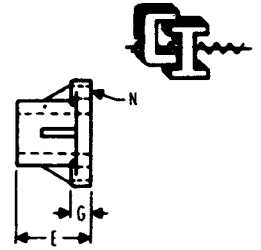
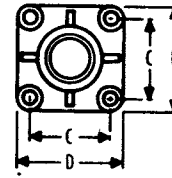

roller bearing flange unit

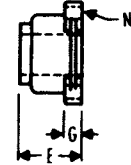
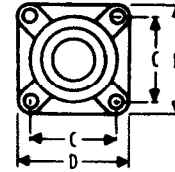

ball bearing flange unit

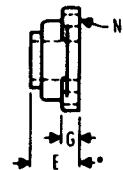
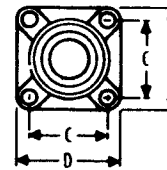

ball bearing discharge unit

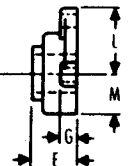
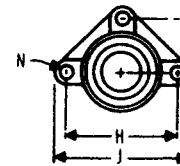

babbitted discharge unit*

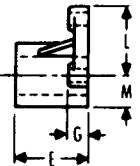
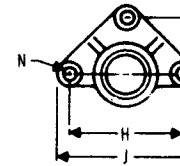

roller bearing pillow block

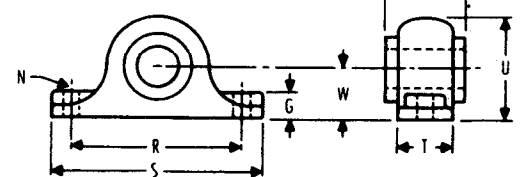

ball bearing pillow block

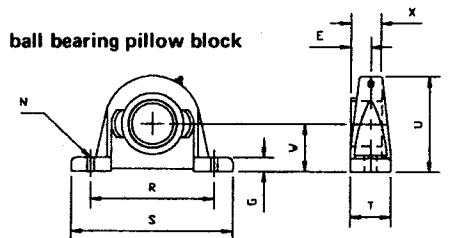

*Bearing Housings can be furnished with other than Babbitt Bearing on application.

THRUST BEARINGS

BRONZE WASHER BEARING

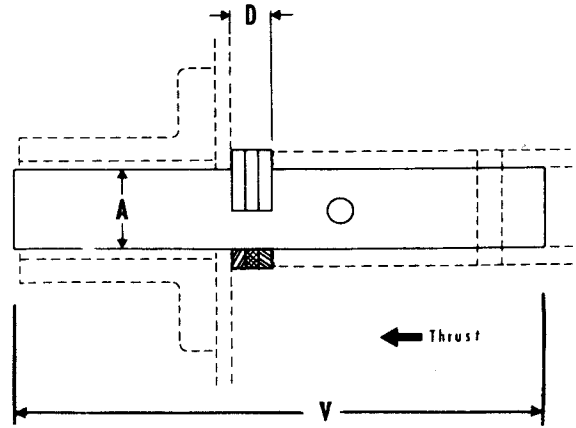
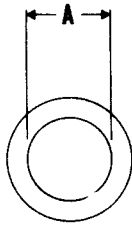
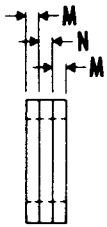

A Shaft Diameter	Part Number	D	M Steel	N Bronze	V	Total Weight
1	TW 1	3/4	1/4	1/8	6-1/8	1
1-1/2	TW 112	1	1/4	1/4	9-1/4	1
2	TW 2	1	1/4	1/4	10-1/4	1
2-7/16	TW 2716	1-1/2	1/4	3/8	11-5/8	1-1/2
3	TW 3	1-1/2	1/4	3/8	12-3/4	2
3-7/16	TW 3716	2	1/4	1/2	15-7/8	3

COLLAR AND WASHER BEARING

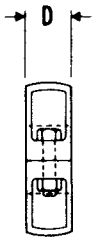

Split collar

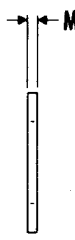
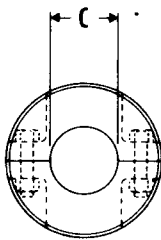

Bronze washer

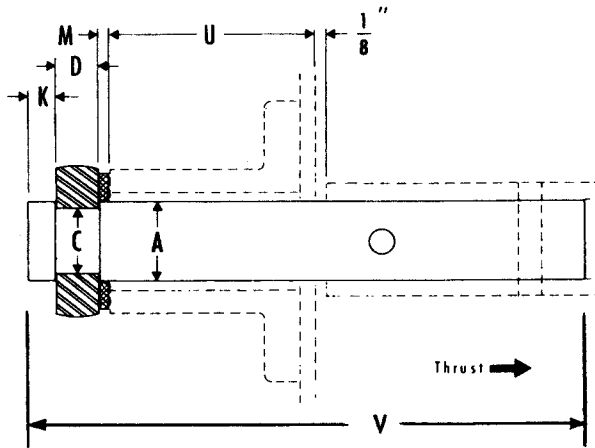
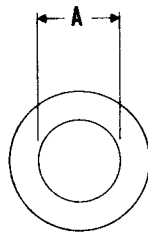

A Shaft Diameter	Part Number	C	D	K	M	U	V	Weight
1	TW 1-C-*	3/4	3/4	3/8	1/8	3	6-5/8	6
1-1/2	TW 112-C-*	1-1/4	15/16	1/2	1/4	4	9-11/16	9
2	TW 2-C-*	1-3/4	1-5/16	1/2	1/4	5	11-1/16	15
2-7/16	TW 2716-C-*	2-3/16	1-5/16	5/8	3/8	5-1/2	12-7/16	24
3	TW 3-C-*	2-11/16	1-5/16	5/8	3/8	5-3/4	13-11/16	39
3-7/16	TW 3716-C-*	2-15/16	1-5/16	7/8	1/2	7	17-1/16	52

*-D Drive Shaft
-E End Shaft

THRUST BEARINGS



Type E roller bearing - Drive Shaft

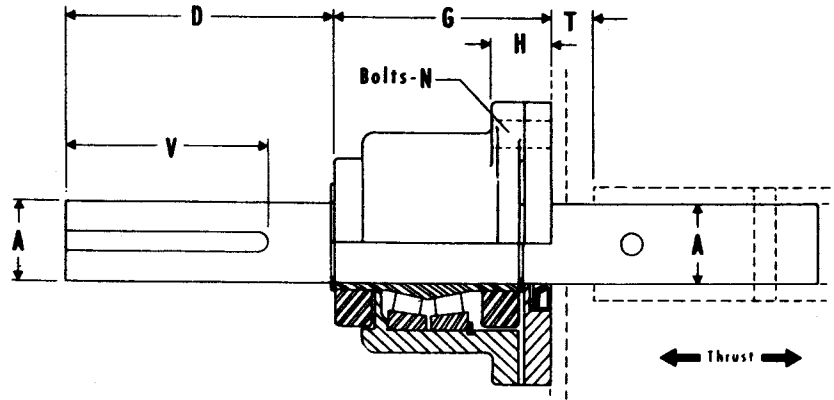
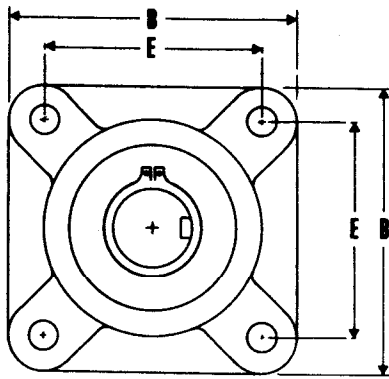

A Shaft Diameter	Part Number	B	D	E	G	H	N	T	V	Weight
1-1/2	TR 112-D	5-3/8	4-1/4	4-1/8	4-1/8	1-13/16	1/2	1-1/4	2-3/4	22
2	TR 2-D	5-5/8	4-3/4	4-3/8	4-1/4	1-13/16	1/2	1-1/4	3-1/4	32
2-7/16	TR 2716-D	6-7/8	5-3/4	5-3/8	4-13/16	2-1/8	5/8	1-13/16	4-1/4	50
3	TR 3-D	7-3/4	6-1/4	6	5-5/16	2-1/4	3/4	1-7/8	4-3/4	73
3-7/16	TR 3716-D	9-1/4	7-1/4	7	5-7/8	2-1/2	3/4	2-3/8	5-3/4	111

Type E roller bearing - End Shaft

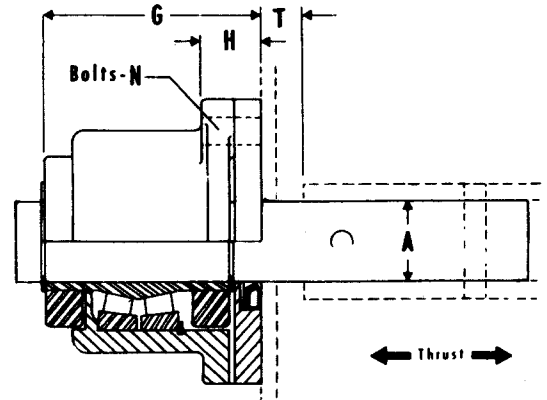
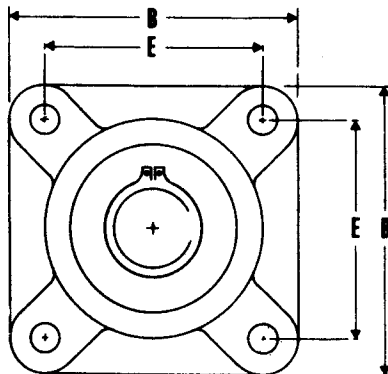

A Shaft Diameter	Part Number	B	E	G	H	N	T	Weight
1-1/2	TR 112-E	5-3/8	4-1/8	4-1/8	1-13/16	1/2	1-1/4	20
2	TR 2-E	5-5/8	4-3/8	4-1/4	1-13/16	1/2	1-1/4	29
2-7/16	TR 2716-E	6-7/8	5-3/8	4-13/16	2-1/8	5/8	1-13/16	44
3	TR 3-E	7-3/4	6	5-5/16	2-1/4	3/4	1-7/8	60
3-7/16	TR 3716-E	9-1/4	7	5-7/8	2-1/2	3/4	2-3/8	88

SHAFT SEALS

WASTE PACKING SEAL

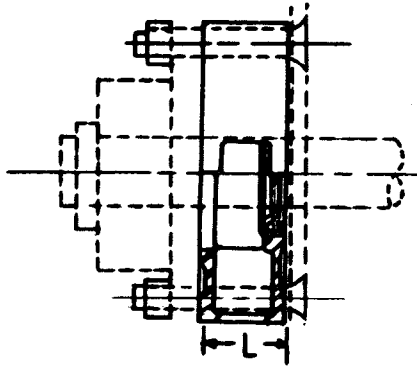
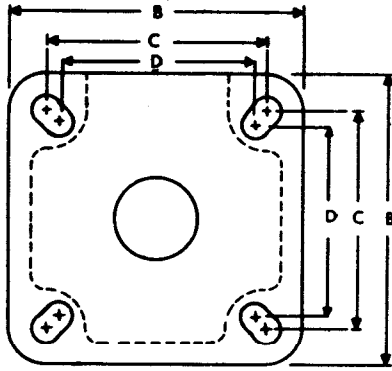

With Lip Seal



With Felt Lip Seal



With Waste Packing

A Shaft Diameter	Part Number	B	C	D	N	L	Weight
1-1/2	SW 112-*	5-3/8	4-1/8	4	1/2	1-3/4	6
2	SW 2-*	6-1/2	5-1/8	4-3/8	5/8	1-3/4	8
2-7/16	SW 2716-*	7-3/8	5-7/8	5-3/8	5/8	1-3/4	10
3	SW 3-*	7-3/4	6	6	3/4	1-3/4	13
3-7/16	SW 3716-*	9-1/4	7	6-3/4	3/4	2-1/4	16
3-15/16	SW 31516-*	10-1/4	7-3/4	7-3/4	7/8	2-1/4	25

PLATE SEAL

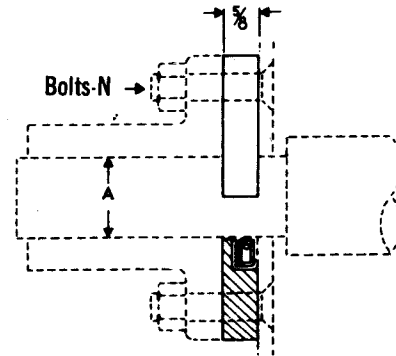
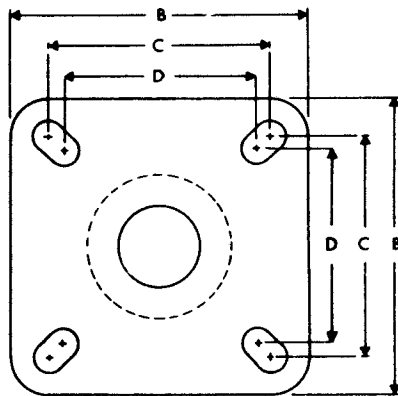

A Shaft Diameter	Part Number	B	C	D	N	Weight
1-1/2	SP 112-*	5-3/8	4-1/8	4	1/2	2
2	SP 2-*	6-1/2	5-1/8	4-3/8	5/8	3
2-7/16	SP 2716-*	7-3/8	5-7/8	5-3/8	5/8	4
3	SP 3-*	7-3/4	6	6	3/4	5
3-7/16	SP 3716-*	9-1/4	7	6-3/4	3/4	8
3-15/16	SP 31516-*	10-1/4	7-3/4	7-3/4	7/8	15

- *W Waste Pack Seal
- *F Felt Seal
- *L Lip Seal

SHAFT SEALS

SPLIT GLAND SEAL

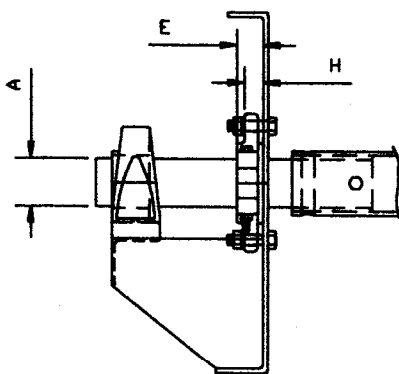
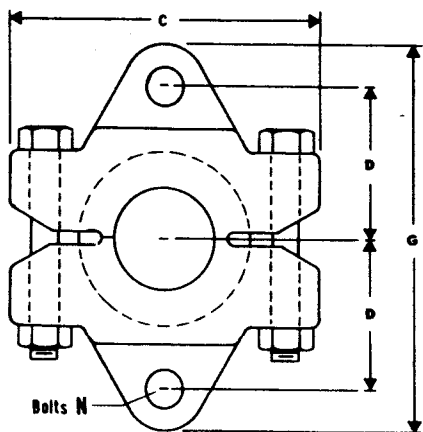

Mounted on outside of pedestal trough end

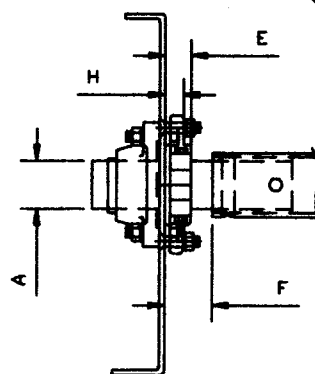

Mounted on inside of trough end

A Shaft Diameter	* Part Number	C	D	E	F	G	H	N	Weight
1-1/2	SS 112	4-9/16	2-3/16	1-7/16	3	5-5/8	7/8	1/2	5
2	SS 2	5-3/8	2-5/8	1-1/2	3	6-1/2	7/8	1/2	10
2-7/16	SS 2716	6-1/8	3-1/16	1-5/8	3	7-5/8	1	5/8	15
3	SS 3	6-3/4	3-9/16	1-5/8	3	8-5/8	1	5/8	22
3-7/16	SS 3716	8-3/4	4-1/8	2-1/8	4	10-1/4	1-1/4	3/4	30
3-15/16	SS 31516	9-1/4	4-1/2	2-1/8	4	11-1/4	1-1/4	7/8	38

FLANGED GLAND SEAL

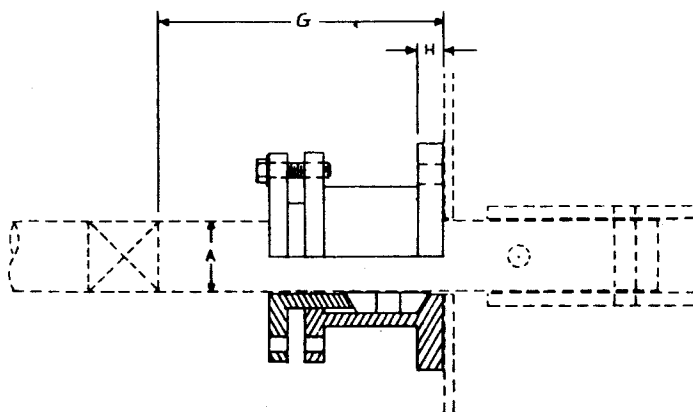
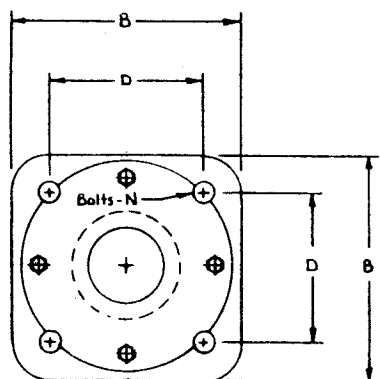

A Shaft Diameter	* Part Number	B	D	G	H	N	Weight
1-1/2	SG 112	5-3/8	4	8	3/4	1/2	11
2	SG 2	6-1/2	5-1/8	8	3/4	5/8	11
2-7/16	SG 2716	7-3/8	5-5/8	8	3/4	5/8	10
3	SG 3	7-3/4	6	8	3/4	3/4	16
3-7/16	SG 3716	9-1/4	6-3/4	8	3/4	3/4	30
3-15/16	SG 31516	10-1/4	7-3/4	8	3/4	7/8	38

* Braided Rope Graphite Packing is Standard. Other Types (Asbestos, Nylon, Teflon, Etc.) Available on Request.

TROUGHS

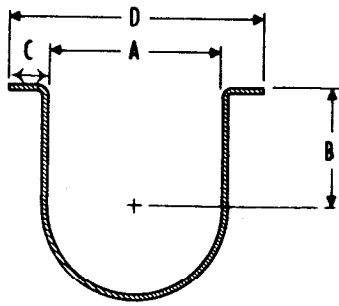

Flanged trough

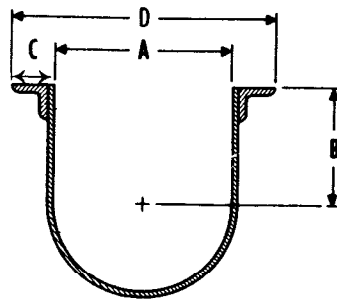

Angle flanged trough

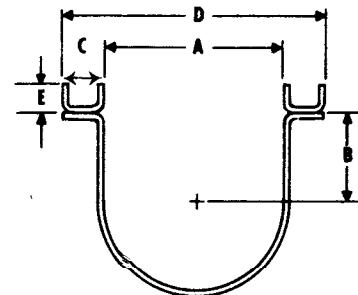

Dust seal trough

Conv Dia	Trough Thick.	Flanged Trough				Angle Flanged Trough				Dust Seal Trough						
		Part Number	Weight		Part Number	Weight		Part Number	Weight		A	B	C	D	E	
			10'lgth	5'lgth		10'lgth	5'lgth		10'lgth	5'lgth						
4	□ 14 12	FT 414	47	25					DST 414	89	49	5	3-5/8	1	7-3/16	1/2
		FT 412	65	34					DST 412	108	58				7-1/4	1/2
6	□ 14 12 3/16	FT 614	65	35	AT 614	89	47		DST 614	106	59	7	4-1/2	1-1/4	9-11/16	1/2
		FT 612	91	48	AT 612	121	62		DST 612	128	70				9-3/4	1/2
		FT 67	145	75	AT 67	163	84		DST 67	180	96				9-7/8	1/2
9	□ 14 12 10 3/16 1/4	FT 914	91	49	AT 914	120	63		DST 914	138	81	10	6-1/8	1-1/2	13-3/16	3/4
		FT 912	130	68	AT 912	150	78		DST 912	168	95				13-1/4	3/4
		FT 910	141	74	AT 910	165	86		DST 910	197	110				13-5/16	3/4
		FT 97	207	107	AT 97	224	115		DST 97	231	132				13-3/8	3/4
		FT 93	273	140	AT 93	284	145		DST 93	297	160				13-1/2	3/4
10	□ 14 12 10 3/16 1/4	FT 1014	97	52	AT 1014	126	66		DST 1014	145	85	11	6-3/8	1-1/2	14-3/16	3/4
		FT 1012	134	69	AT 1012	157	82		DST 1012	177	101				14-1/4	3/4
		FT 1010	152	78	AT 1010	188	97		DST 1010	201	111				14-5/16	3/4
		FT 107	222	114	AT 107	239	123		DST 107	245	140				14-3/8	3/4
		FT 103	292	149	AT 103	303	155		DST 103	318	172				14-1/2	3/4
			12'lgth.	6'lgth.		12'lgth.	6'lgth.		12'lgth.	6'lgth.						
12	□ 12 ga. 10 3/16 1/4	FT 1212	197	154	AT 1212	236	124		DST 1212	255	133	13	7-3/4	2	17-1/4	1
		FT 1210	224	118	AT 1210	281	146		DST 1210	303	157				17-5/16	1
		FT 127	326	169	AT 127	353	182		DST 127	368	190				17-3/8	1
		FT 123	428	220	AT 123	446	229		DST 123	460	236				17-1/2	1
14	□ 12 ga. 10 3/16 1/4	FT 1412	219	116	AT 1412	257	135		DST 1412	276	145	15	9-1/4	2	19-1/4	1
		FT 1410	248	131	AT 1410	309	162		DST 1410	327	170				19-5/16	1
		FT 147	365	189	AT 147	394	204		DST 147	405	209				19-3/8	1
		FT 143	483	248	AT 143	501	257		DST 143	513	263				19-1/2	1
16	□ 12 ga. 10 3/16 1/4	FT 1612	247	131	AT 1612	285	150		DST 1612	319	167	17	10-5/8	2	21-1/4	1
		FT 1610	281	148	AT 1610	345	180		DST 1610	373	194				21-5/16	1
		FT 167	414	215	AT 167	442	229		DST 167	458	237				21-3/8	1
		FT 163	546	281	AT 163	565	290		DST 163	579	297				21-1/2	1
18	□ 12 ga. 10 3/16 1/4	FT 1812	284	153	AT 1812	356	189		DST 1812	373	197	19	12-1/8	2-1/2	24-1/4	1
		FT 1810	323	172	AT 1810	423	222		DST 1810	441	231				24-5/16	1
		FT 187	473	247	AT 187	533	277		DST 187	557	289				24-3/8	1
		FT 183	624	323	AT 183	671	346		DST 183	684	353				24-1/2	1
20	□ 10 ga. 3/16 1/4	FT 2010	355	189	AT 2010	460	242		DST 2010	501	262	21	13-1/2	2-1/2	26-5/16	1
		FT 207	521	272	AT 207	581	302		DST 207	620	322				26-3/8	1
		FT 203	687	355	AT 203	734	379		DST 203	762	393				26-1/2	1
24	□ 10 ga. 3/16 1/4	FT 2410	461	244	AT 2410	531	279		DST 2410	593	310	25	16-1/2	2-1/2	30-5/16	1
		FT 247	617	322	AT 247	676	352		DST 247	737	382				30-3/8	1
		FT 243	813	420	AT 243	860	444		DST 243	897	461				30-1/2	1

□ Standard gauge.

TROUGHS

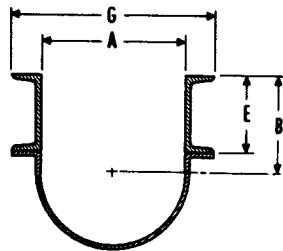

Channel trough

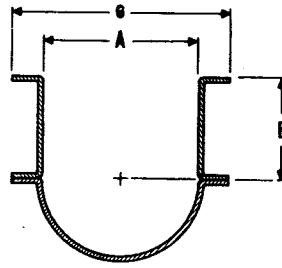

Formed channel trough

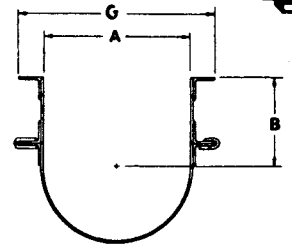

Drop Bottom



Screw Dia	Part Number			Thick-ness Ga.	A	B	E	G	Weight Per Foot		
	Channel	Formed Channel	Drop Bottom						Channel	Formed Channel	Drop Bottom
6	CT 612	FCT 612	DBT 612	12	7	4-1/2	4	10-1/4	15.9	10.9	11
9	CT 912	FCT 912	DBT 912	12	10	6-1/8	6	13-3/4	23.5	15.3	17
12	CT 1212	FCT 1212	DBT 1212	12	13	7-3/4	7	17-1/4	29.2	20.9	20
14	CT 1412	FCT 1412	DBT 1412	12	15	9-1/4	9	19-3/4	37.6	22.5	23
16	CT 1610	FCT 1610	DBT 1610	10	17	10-5/8	10	22-1/4	45.9	31.7	31
18	CT 1810	FCT 1810	DBT 1810	10	19	12-1/8	12	25	59.0	38.9	35
20	CT 2010	FCT 2010	DBT 2010	10	21	13-1/2	12	27	60.5	43.3	36
24	CT 2410	FCT 2410	DBT 2410	10	25	16-1/2	15	31-3/4	90.1	50.8	41

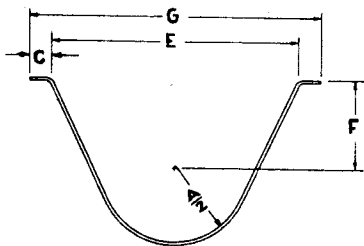

Flared-formed flange

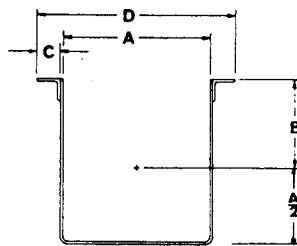

Rectangular angle flanged

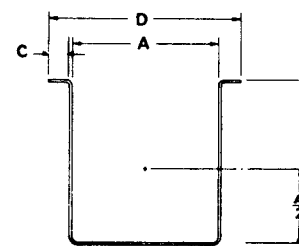

Rectangular formed flange

Screw Dia	Thick-ness Ga.	Part Number						A	B	C	D	E	F	G	
		Flared	Wt. Ft.	Rect. Angle Fig'd.	Wt. Ft.	Rect. Formed Flg.	Wt. Ft.								
6	14	VT 614	7.9	RAT 614	10.3	RFT 614	6.6	7	4-1/2	1-1/4	9-11/16	14	7	16-5/8	
	12	VT 612	10.8	RAT 612	12.5	RFT 612	9.1								9-3/4
9	14	VT 914	12.6	RAT 914	13.0	RFT 914	9.8	10	6-1/8	1-1/2	13-3/16	18	9	21-1/4	
	12	VT 912	14.6	RAT 912	16.1	RFT 912	13.4								13-1/4
	10	VT 910	18.5	RAT 910	19.2	RFT 910	17.2								13-5/16
	3/16	VT 97	22	RAT 97	24.8	RFT 97	22.8								13-3/8
12	12	VT 1212	14.8	RAT 1212	21.8	RFT 1212	17.0	13	7-3/4	2	17-1/4	22	10	26-1/4	
	10	VT 1210	18.7	RAT 1210	26.0	RFT 1210	21.6								17-5/16
	3/16	VT 127	25.7	RAT 127	31.6	RFT 127	29.1								17-3/8
14	12	VT 1412	16.4	RAT 1412	24.0	RFT 1412	19.2	15	9-1/4	2	19-1/4	24	11	28-1/4	
	10	VT 1410	20.7	RAT 1410	28.8	RFT 1410	24.5								19-5/16
	3/16	VT 147	28.4	RAT 147	35.5	RFT 147	33.0								19-3/8
16	12	VT 1610	22.7	RAT 1612	26.2	RFT 1612	21.4	17	10-5/8	2	21-1/4	28	11-1/2	32-1/4	
	10	VT 1610	31.1	RAT 1610	31.6	RFT 1610	27.3								21-5/16
	3/16	VT 167	31.1	RAT 167	41.1	RFT 167	37.5								21-3/8
	1/4	VT 163	32.8	RAT 163	52.7	RFT 163	50.2								21-1/2
18	12	VT 1810	25.2	RAT 1812	31.1	RFT 1812	24.8	19	12-1/8	2-1/2	24-1/4	31	12-1/8	36-1/4	
	10	VT 1810	34.4	RAT 1810	37.3	RFT 1810	31.5								24-5/16
	3/16	VT 187	34.4	RAT 187	48.2	RFT 187	43.2								24-3/8
	1/4	VT 183	45.3	RAT 183	60.8	RFT 183	57.6								24-1/2
20	12	VT 2010	26.7	RAT 2012	34.6	RFT 2012	28.3	21	13-1/2	2-1/2	26-1/4	34	13-1/2	39-1/4	
	10	VT 2010	36.4	RAT 2010	41.8	RFT 2010	36.0								26-5/16
	3/16	VT 207	36.4	RAT 207	54.4	RFT 207	49.5								26-3/8
	1/4	VT 203	48.0	RAT 203	69.8	RFT 203	66.0								26-1/2
24	12	VT 2410	30.8	RAT 2412	43.4	RFT 2412	37.4	25	16-1/2	2-1/2	30-1/4	40	16-1/2	45-1/4	
	10	VT 2410	42.0	RAT 2410	53.0	RFT 2410	47.5								30-5/16
	3/16	VT 247	42.0	RAT 247	69.8	RFT 247	65.3								30-3/8
	1/4	VT 243	55.7	RAT 243	90.8	RFT 243	87.0								30-1/2

TUBULAR HOUSINGS

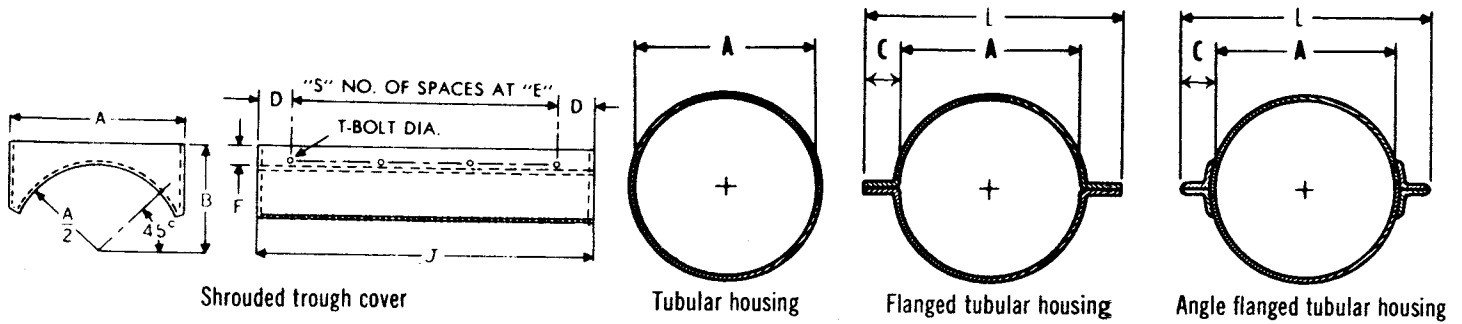

Conv. Dia.	Thick-ness Ga.	Shrouded Trough Cover		Tubular Housing		Flanged Tubular Housing		Angle Flanged Tubular Housing		A	B	C	L	D	E	S	T	F	J			
		Part Number	Wt.	Part Number	Weight		Part Number	Weight												Part Number	Weight	
					10'	5'		10'	5'												10'	5'
4	□ 14" 12	TS 414 TS 412	2.0	TH 414 TH 412	43 60	22 31	FTH 414 FTH 412	53 74	27 38	ATH 414 ATH 412	89 106	45 54	5	3-5/8	1	7-3/16 7-1/4	2	4	1	3/8	5/8	8
6	□ 14" 12* 3/16	TS 614 TS 612 TS 67	3.9 5.4	TH 614 TH 612 TH 67	62 85 145	33 44 74	FTH 614 FTH 612 FTH 67	75 103 168	40 53 86	ATH 614 ATH 612 ATH 67	122 145 205	63 74 104	7	4-1/2	1 1/4	9-11/16 9-3/4 9-7/8	3	6	1	3/8	3/4	12
9	□ 14" 12 10 3/16* 1/4	TS 914 TS 912 TS 910 TS 97 TS 93	7.8 19	TH 914 TH 912 TH 910 TH 97 TH 93	89 122 155 208 275	47 64 80 107 140	FTH 914 FTH 912 FTH 910 FTH 97 FTH 93	104 143 182 245 324	55 75 94 126 165	ATH 914 ATH 912 ATH 910 ATH 97 ATH 93	161 194 227 280 347	83 100 116 143 176	10	6-1/8	1 1/4	13-3/16 13-1/4 13-5/16 13-3/8 13-1/2	3	6	2	3/8	7/8	18
10	□ 14" 12 10 3/16* 1/4	TS1014 TS1012 TS1010 TS 107 TS 103	9.4 23	TH1014 TH1012 TH1010 TH 107 TH 103	97 133 169 227 301	52 70 88 117 154	FTH1014 FTH1012 FTH1010 FTH 107 FTH 103	112 154 196 264 350	60 81 102 136 179	ATH1014 ATH1012 ATH1010 ATH 107 ATH 103	169 205 241 299 373	88 106 124 153 190	11	6-3/8	1 1/4	14-3/16 14-1/4 14-5/16 14-3/8 14-1/2	2 1/2	5	3	3/8	7/8	20
					12'	6'		12'	6'		12'	6'										
12	□ 12" 10 3/16* 1/4	TS1212 TS1210 TS 127 TS 123	19 33	TH1212 TH1210 TH 127 TH 123	195 248 329 434	103 130 171 223	FTH1212 FTH1210 FTH 127 FTH 123	231 295 392 518	121 153 202 265	ATH1212 ATH1210 ATH 127 ATH 123	313 366 447 552	162 189 229 282	13	7-3/4	2	17-1/4 17-5/16 17-3/8 17-1/2	3	6	3	3/8	1-1/8	24
14	□ 12" 10 3/16* 1/4	TS1412 TS1410 TS 147 TS 143	26 47	TH1412 TH1410 TH 147 TH 143	223 282 327 498	118 148 196 256	FTH1412 FTH1410 FTH 147 FTH 143	259 329 441 582	137 172 227 298	ATH1412 ATH1410 ATH 147 ATH 143	341 400 496 616	177 207 255 315	15	9-1/4	2	19-1/4 19-5/16 19-3/8 19-1/2	3 1/2	7	3	3/8	1-1/8	28
16	□ 12" 10 3/16* 1/4	TS1612 TS1610 TS 167 TS 163	35 62	TH1612 TH1610 TH 167 TH 163	254 320 428 566	135 168 222 291	FTH1612 FTH1610 FTH 167 FTH 163	290 367 493 650	153 191 254 333	ATH1612 ATH1610 ATH 167 ATH 163	372 438 546 684	194 227 281 350	17	10-5/8	2	21-1/4 21-5/16 21-3/8 21-1/2	4	8	3	3/8	1-1/8	32
18	□ 12" 10 3/16* 1/4	TS1812 TS1810 TS 187 TS 183	45 79	TH1812 TH1810 TH 187 TH 183	290 378 485 639	156 193 253 331	FTH1812 FTH1810 FTH 187 FTH 183	336 423 566 746	179 222 294 384	ATH1812 ATH1810 ATH 187 ATH 183	437 511 632 786	229 266 327 404	19	12-1/8	2 1/2	24-1/4 24-5/16 24-3/8 24-1/2	4 1/2	9	3	3/8	1-3/8	36
20	□ 10" 3/16* 1/4	TS2010 TS 207 TS 203	71 99	TH2010 TH 207 TH 203	401 534 702	212 286 363	FTH2010 FTH 207 FTH 203	458 612 806	241 318 415	ATH2010 ATH 207 ATH 203	548 681 849	286 352 437	21	13-1/2	2 1/2	26-5/16 26-3/8 26-1/2	4	8	4	3/8	1-3/8	40
24	□ 10" 3/16* 1/4	TS2410 TS 247 TS 243	104 144	TH2410 TH 247 TH 243	477 637 837	252 332 432	FTH2410 FTH 247 FTH 243	534 713 941	281 370 484	ATH2410 ATH 247 ATH 243	626 784 986	327 406 507	25	16-1/2	2 1/2	30-5/16 30-3/8 30-1/2	4	8	5	3/8	1-3/8	48

□ Standard gauge.
*Standard shroud gauge.

See Page 36 for Hanger Pockets used on Tubular Trough.

TUBULAR HOUSING FLANGES

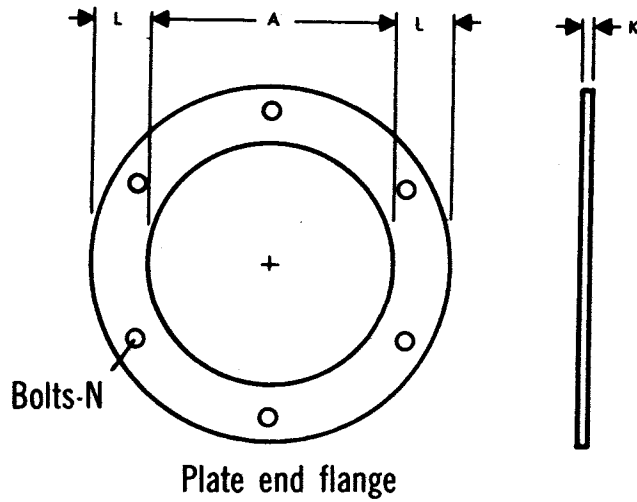

Conv. Dia.	Max. Thickness *	Part Number		Weight Plate End Flange
		Plate End Flange	Gaskets	
4	10 ga.	TFP 410-H	GT4-**	1.0
	1/4 ga.	TFP 43-H		
6	10 ga.	TFP 610-H	GT6-**	1.8
	1/4 ga.	TFP 63-H		
9	10 ga.	TFP 910-H	GT9-**	3.0
	1/4 ga.	TFP 93-H		
10	10 ga.	TFP 1010-H	GT10-**	3.2
	1/4 ga.	TFP 103-H		
12	10 ga.	TFP 1210-H	GT12-**	6.9
	1/4 ga.	TFP 123-H		
14	10 ga.	TFP 1410-H	GT14-**	7.7
	1/4 ga.	TFP 143-H		
16	10 ga.	TFP 1610-H	GT16-**	8.6
	1/4 ga.	TFP 163-H		
18	10 ga.	TFP 1810-H	GT18-**	12.0
	1/4 ga.	TFP 183-H		
20	10 ga.	TFP 2010-H	GT20-**	13.1
	1/4 ga.	TFP 203-H		
24	10 ga.	TFP 2410-H	GT24-**	15.3
	1/4 ga.	TFP 243-H		

**Material: RR (Red Rubber), BN (Black Neoprene), WN (White Nitrile), etc.

DIMENSIONS

Conv. Dia.	A		D	K	L	N
	Thru 10 ga.	3/16 and 1/4 in. *				
4	5-1/4	5-3/8	1	3/16	1-1/4	3/8
6	7-1/4	7-3/8	1-1/4	3/16	1-1/4	3/8
9	10-1/4	10-1/2	1-1/2	3/16	1-1/2	3/8
10	11-1/4	11-1/2	1-1/2	3/16	1-1/2	3/8
12	13-1/4	13-1/2	2	1/4	2	1/2
14	15-1/4	15-1/2	2	1/4	2	1/2
16	17-1/4	17-1/2	2	1/4	2	5/8
18	19-1/4	19-1/2	2-1/2	1/4	2-1/2	5/8
20	21-1/4	21-1/2	2-1/2	1/4	2-1/2	5/8
24	25-1/4	25-1/2	2-1/2	1/4	2-1/2	5/8

*Trough Thickness.
For Bolt pattern see page 65.

TROUGH FLANGES

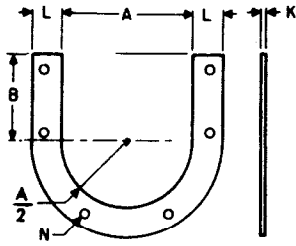
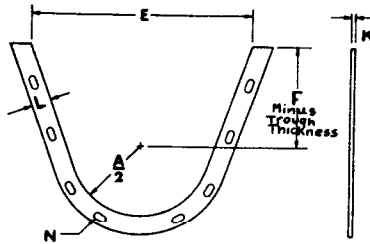
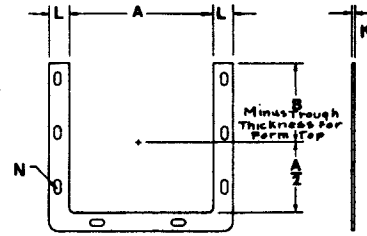

Plate End Flange



Flared End Flange



Rectangular End Flange

Conv. Diam.	Max. Trough Thickness	Part Number						
		Plate End Flange	Wt.	Plate End Flange Flared	Wt.	Rectangular End Flange	Wt.	U-Flange Gaskets
4	10 ga. 1/4 ga.	FP 410-U FP 43-U	0.9	—	—	FP4R	1.0	GU4-**
6	10 ga. 1/4 ga.	FP 610-U FP 63-U	1.5	FP 6F	1.9	FP6R	1.7	GU6-**
9	10 ga. 1/4 ga.	FP 910-U FP 93-U	2.4	FP 9F	3.0	FP9R	2.9	GU9-**
10	10 ga. 1/4 ga.	FP1010-U FP 103-U	2.6	—	—	FP10R	3.1	GU10-**
12	10 ga. 1/4 ga.	FP1210-U FP 123-U	5.6	FP12F	6.4	FP12R	6.6	GU12-**
14	10 ga. 1/4 ga.	FP1410-U FP 143-U	6.5	FP14F	7.3	FP14R	7.6	GU14-**
16	10 ga. 1/4 ga.	FP1610-U FP 163-U	7.4	FP16F	7.9	FP16R	8.5	GU16-**
18	10 ga. 1/4 ga.	FP1810-U FP 183-U	10.2	FP18F	10.8	FP18R	12.1	GU18-**
20	10 ga. 1/4 ga.	FP2010-U FP 203-U	11.3	FP20F	11.4	FP20R	13.3	GU20-**
24	10 ga. 1/4 ga.	FP2410-U FP 243-U	15.5	FP24F	13.0	FP24R	15.8	GU24-**

**Material: RR (Red Rubber), BN (Black Neoprene), WN (White Nitrile), etc.

DIMENSIONS

Conv. Diam.	A		B	D	E		F	K	L		N
	Thru 10 ga.	3/16 and 1/4 in.			Up to 10 ga.	3/16 & 1/4			Up to 10 ga.	3/16 & 1/4	
4	5-1/4	5-3/8	3-5/8	1	—	—	—	3/16	1-1/4	—	3/8
6	7-1/4	7-3/8	4-1/2	1-1/4	14-1/4	14-1/2	7	3/16	1-1/4	1-1/4	3/8
9	10-1/4	10-1/2	6-1/8	1-1/2	18-1/4	18-1/2	9	3/16	1-3/4	1-1/2	3/8
10	11-1/4	11-1/2	6-3/8	1-1/2	—	—	—	3/16	1-3/4	1-1/2	3/8
12	13-1/4	13-1/2	7-3/4	2	22-1/4	22-1/2	10	1/4	2	2	1/2
14	15-1/4	15-1/2	9-1/4	2	24-1/4	24-1/2	11	1/4	2	2	1/2
16	17-1/4	17-1/2	10-5/8	2	28-1/4	28-1/2	11-1/2	1/4	2	2	5/8
18	19-1/4	19-1/2	12-1/8	2-1/2	31-1/4	31-1/2	12-1/8	1/4	2-1/2	2-1/2	5/8
20	21-1/4	21-1/2	13-1/2	2-1/2	34-1/4	34-1/2	13-1/2	1/4	2-1/2	2-1/2	5/8
24	25-1/4	25-1/2	16-1/2	2-1/2	40-1/4	40-1/2	16-1/2	1/4	2-1/2	2-1/2	5/8

*Trough Thickness.

For Bolt pattern see page 64.

TROUGH SADDLES & FEET

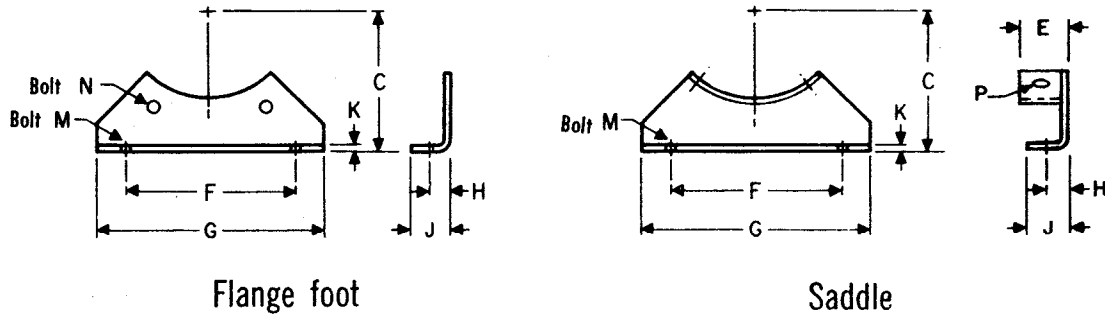

Conv. Diam.	Part Number		Weight	
	Saddle	Flange Foot	Saddle	Flange Foot
4	S 4	FF 4	1.5	1.5
6	S 6	FF 6	2.0	2.0
9	S 9	FF 9	4.5	4.5
10	S10	FF10	5.0	5.0
12	S12	FF12	6.0	6.0
14	S14	FF14	7.0	7.0
16	S16	FF16	8.0	7.5
18	S18	FF18	10.0	9.5
20	S20	FF20	13.0	12.5
24	S24	FF24	15.0	14.5

DIMENSIONS

Conv. Diam.	C	E	F	G	H	J	K	M	N	P
4	4-5/8	1-3/16	5-3/4	7-3/8	7/8	1-1/2	3/16	3/8	3/8	1/4
6	5-5/8	1-3/16	8-1/8	10	13/16	1-1/2	3/16	3/8	3/8	1/4
9	7-7/8	1-1/2	9-3/8	12	1-5/16	2-1/2	3/16	1/2	3/8	3/8
10	8-7/8	1-1/2	9-1/2	12-3/8	1-9/16	2-1/2	3/16	5/8	3/8	3/8
12	9-5/8	1-1/2	12-1/4	15	1-3/8	2-1/2	1/4	5/8	1/2	1/2
14	10-7/8	1-3/4	13-1/2	16-1/2	1-3/8	2-1/2	1/4	5/8	1/2	1/2
16	12	1-3/4	14-7/8	18	1-3/4	3	1/4	5/8	5/8	1/2
18	13-3/8	1-3/4	16	19-1/8	1-3/4	3	1/4	5/8	5/8	1/2
20	15	2-1/4	19-1/4	22-3/4	2	3-1/2	1/4	3/4	5/8	5/8
24	18-1/8	2-1/4	20	24	2-1/4	4	1/4	3/4	5/8	5/8

DISCHARGE SPOUTS



plain opening

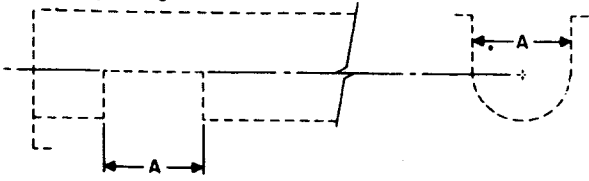

fixed spout with slide gate

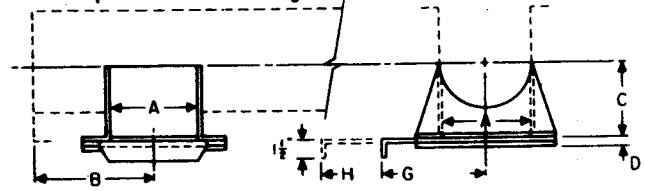

fixed spout flared trough

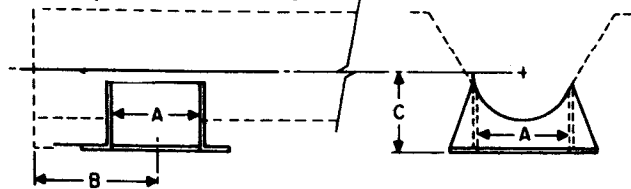

Flush end Spout

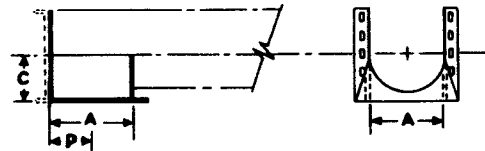

fixed spout

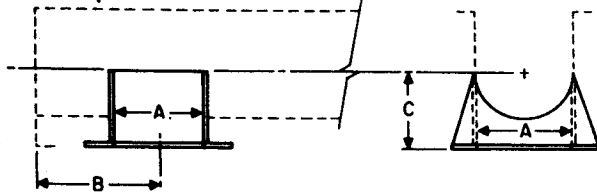

Note: Trough end forms the 4th side of a Flush End Spout.

Screw Diam.	A	B Minimum	C	D	G	H	P
4	5	4-1/2	3-3/4	5/16	5-5/8	11	2-1/2
6	7	6	5	5/16	6-5/8	14	3-1/2
9	10	8	7-1/8	5/16	8	19	5
10	11	9	7-7/8	5/16	8-3/8	20	5-1/2
12	13	10-1/2	8-7/8	5/16	10-1/8	24	6-1/2
14	15	11-1/2	10-1/8	5/16	11-1/4	27	7-1/2
16	17	13-1/2	11-1/8	5/16	12-3/8	30	8-1/2
18	19	14-1/2	12-3/8	5/16	13-3/8	33	9-1/2
20	21	15-1/2	13-3/8	3/8	14-3/8	36	10-1/2
24	25	17-1/2	15-3/8	3/8	16-3/8	42	12-1/2

Screw Diam.	Part Number		
	Fixed Spout		Flush End Spout
	Plain	With Slide	
4	DS4 *	DS4 * - S	DS4 * - F
6	DS6 *	DS6 * - S	DS6 * - F
9	DS9 *	DS9 * - S	DS9 * - F
10	DS10 *	DS10 * - S	DS10 * - F
12	DS12 *	DS12 * - S	DS12 * - F
14	DS14 *	DS14 * - S	DS14 * - F
16	DS16 *	DS16 * - S	DS16 * - F
18	DS18 *	DS18 * - S	DS18 * - F
20	DS20 *	DS20 * - S	DS20 * - F
24	DS24 *	DS24 * - S	DS24 * - F

* Same thickness as trough on which spout will be mounted
14 (14 ga.), 12 (12 ga.), 10 (10 ga.), 7 (3/16"), 3 (1/4")

Note: For Bolt Patterns see Page 65.

DISCHARGE GATES

PNEUMATIC FLAT SLIDE

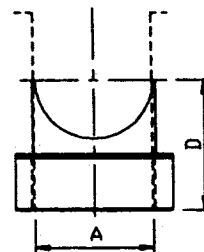
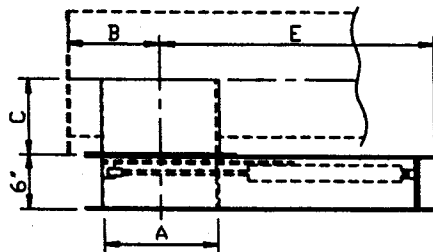

RACK AND PINION FLAT SLIDE

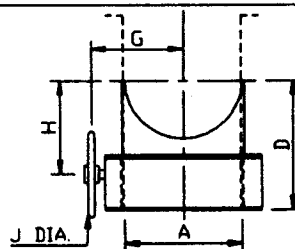
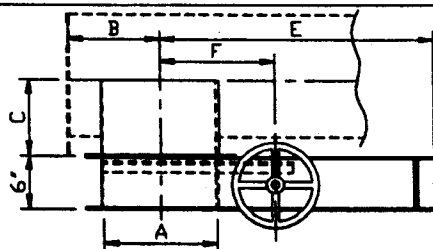

SCREW DIAM.	A	B	C	D	E	F	G	H	J
4	5	4-1/2	3-3/4	9-1/4	21-9/16	9-1/2	5	6-3/4	12
6	7	6	5	11	22-13/16	11-1/2	6	8-1/2	12
9	10	8	7-1/8	13-1/8	30	12	9-1/2	10-5/8	12
10	11	9	7-7/8	13-7/8	30-1/2	12-1/2	10	11-3/8	12
	13	10-1/2	8-7/8	14-7/8	36	13-1/2	12-1/4	12-3/8	12
14	15	11-1/2	10-1/8	16-1/8	37	14-1/2	13-1/4	13-5/8	12
16	17	12-1/2	11-1/8	17-1/8	43-1/2	15-1/2	14-1/4	14-5/8	12
18	19	14-1/2	12-3/8	18-3/8	44-3/4	16-1/2	15-3/4	15-7/8	12
20	21	15-1/2	13-3/8	19-3/8	47-3/4	17-1/2	16-3/4	16-7/8	12
24	25	17-1/2	15-3/8	21-3/8	53-3/4	19-1/2	18-3/4	18-7/8	12
SCREW DIAM.	GATE THK.	PART NUMBER		CYLINDER		DUST TIGHT **PART NUMBER			
		RACK & PINION	PNEUMATIC	STROKE	SIZE	RACK & PINION	PNEUMATIC		
4	3/16 1/4	RP47-F* RP43-F*	PRP47-F PRP43-F	8	1-1/2	RP47-FD* RP43-FD*	PRP47-FD PRP43-FD		
6	3/16 1/4	RP67-F* RP63-F*	PRP67-F PRP63-F	8	1-1/2	RP67-FD* RP63-FD*	PRP67-FD PRP63-FD		
9	3/16 1/4	RP97-F* RP93-F*	PRP97-F PRP93-F	12	2	RP97-FD* RP93-FD*	PRP97-FD PRP93-FD		
10	3/16 1/4	RP107-F* RP103-F*	PRP107-F PRP103-F	12	2	RP107-FD* RP103-FD*	PRP107-FD PRP103-FD		
12	3/16 1/4	RP127-F* RP123-F*	PRP127-F PRP123-F	16	2	RP127-FD* RP123-FD*	PRP127-FD PRP123-FD		
14	3/16 1/4	RP147-F* RP143-F*	PRP147-F PRP143-F	16	2	RP147-FD* RP143-FD*	PRP147-FD PRP143-FD		
16	3/16 1/4	RP167-F* RP163-F*	PRP167-F PRP163-F	20	2-1/2	RP167-FD* RP163-FD*	PRP167-FD PRP163-FD		
18	3/16 1/4	RP187-F* RP183-F*	PRP187-F PRP183-F	20	2-1/2	RP187-FD* RP183-FD*	PRP187-FD PRP183-FD		
20	3/16 1/4	RP207-F* RP203-F*	PRP207-F PRP203-F	22	2-1/2	RP207-FD* RP203-FD*	PRP207-FD PRP203-FD		
24	3/16 1/4	RP247-F* RP243-F*	PRP247-F PRP243-F	26	2-1/2	RP247-FD* RP243-FD*	PRP247-FD PRP243-FD		

* Handwheel supplied as standard assembly
 -C Chain wheel
 -R Rope wheel

** Gates are completely enclosed if "dust tight".

DISCHARGE GATES



rack and pinion curved slide

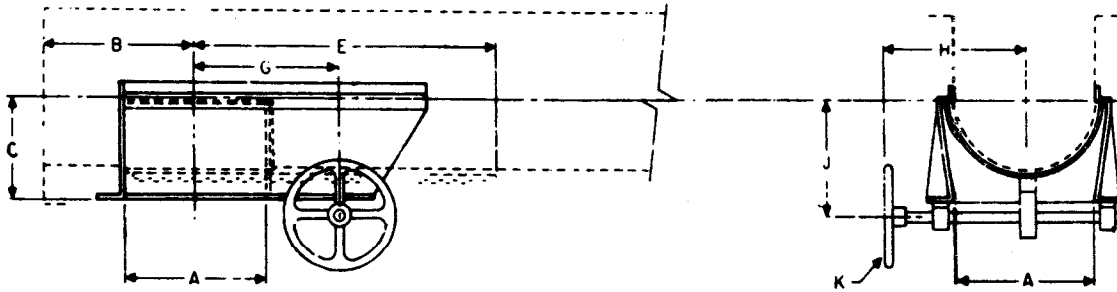

pneumatic curved slide

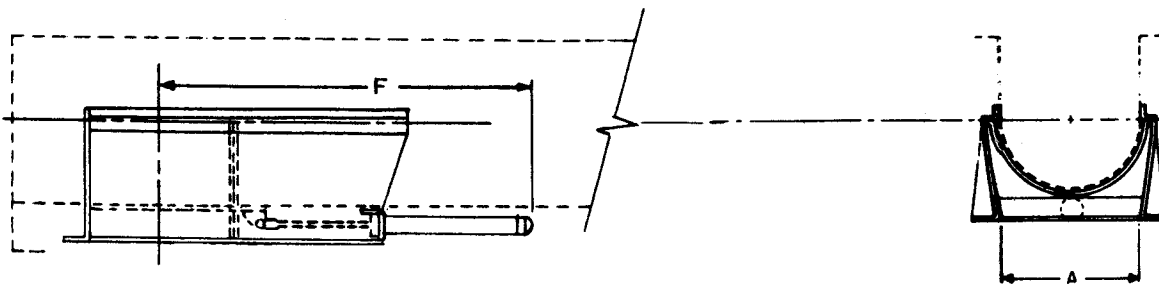

Screw Diam.	A	B Minimum	C	E	F	G	H	J	K Diam.
4	5	4-1/2	3-3/4	20-1/4	25-5/8	7-1/2	5	6	12
6	7	6	5	23-1/4	29-5/8	8-1/2	6	6-3/4	12
9	10	8	7-1/8	27-3/4	39-1/16	10	9-1/2	8-7/8	12
10	11	9	7-7/8	29-1/4	40-9/16	10-1/2	10	9-3/4	12
12	13	10-1/2	8-7/8	32-1/4	47-13/16	11-1/2	12-1/4	10-3/4	12
14	15	11-1/2	10-1/8	35-1/4	50-13/16	12-1/2	13-1/4	12	12
16	17	13-1/2	11-1/8	38-1/4	58-9/16	13-1/2	14-1/4	13	12
18	19	14-1/2	12-3/8	41-1/4	61-9/16	14-1/2	15-3/4	14-1/8	12
20	21	15-1/2	13-3/8	44-1/4	66-13/16	15-1/2	16-3/4	15-1/8	12
24	25	17-1/2	15-3/8	60-1/4	76-13/16	17-1/2	18-3/4	17-3/8	12

Screw Diam.	Trough Thick. ga.	Spout & Slide Thick. ga.	Part Number		Weight		Cylinder	
			Rack & Pinion	Pneumatic	Rack and Pinion	Pneumatic	Stroke	Size
4	14 12	□ 14 12	RP 414 -C*	PRP 414 -C	20	26	8	1-1/2
			RP 412 -C*	PRP 412 -C	22	38		
6	14-12 3/16	□ 14 12	RP 614 -C*	PRP 614 -C	25	48	8	1-1/2
			RP 612 -C*	PRP 612 -C	28	44		
9	14-12-10 3/16 - 1/4	□ 14 10	RP 914 -C*	PRP 914 -C	46	64	12	2
			RP 910 -C*	PRP 910 -C	54	72		
10	14-12-10 3/16 - 1/4	□ 14 10	RP 1014 -C*	PRP 1014 -C	53	72	12	2
			RP 1010 -C*	PRP 1010 -C	62	81		
12	12-10 3/16 - 1/4	□ 12 3/16	RP 1212 -C*	PRP 1212 -C	81	111	16	2
			RP 127 -C*	PRP 127 -C	97	117		
14	12-10 3/16 - 1/4	□ 12 3/16	RP 1412 -C*	PRP 1412 -C	95	120	16	2
			RP 147 -C*	PRP 147 -C	114	139		
16	12-10 3/16 - 1/4	□ 12 3/16	RP 1612 -C*	PRP 1612 -C	103	133	20	2-1/2
			RP 167 -C*	PRP 167 -C	116	146		
18	12-10 3/16 - 1/4	□ 12 3/16	RP 1812 -C*	PRP 1812 -C	157	192	20	2-1/2
			RP 187 -C*	PRP 187 -C	187	222		
20	10 3/16 - 1/4	□ 12 3/16	RP 2012 -C*	PRP 2012 -C	175	215	22	2-1/2
			RP 207 -C*	PRP 207 -C	208	248		
24	10 3/16 - 1/4	□ 12 3/16	RP 2412 -C*	PRP 2412 -C	220	265	26	2-1/2
			RP 247 -C*	PRP 247 -C	265	310		

* Handwheel supplied as standard assembly.
 - C Chain Wheel
 - R Rope Wheel

□ Denotes Standard Gauges.
 For Bolt Pattern see Page 65.
 All Rack & Pinion Gates 18" and Larger to Have Double Rack & Pinion.

DISCHARGE GATES



dust tight rack and pinion flat slide

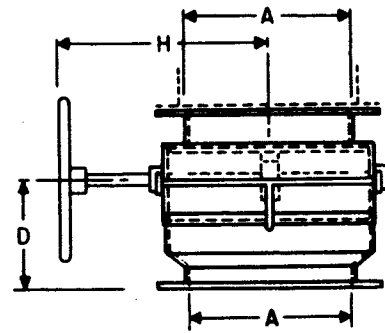
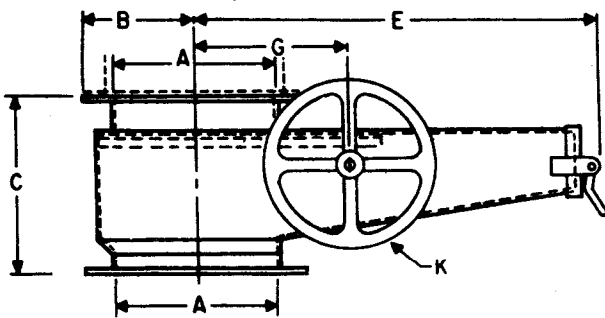

dust tight pneumatic flat slide

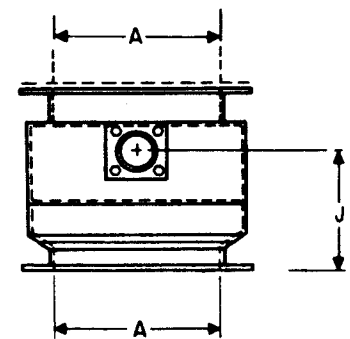
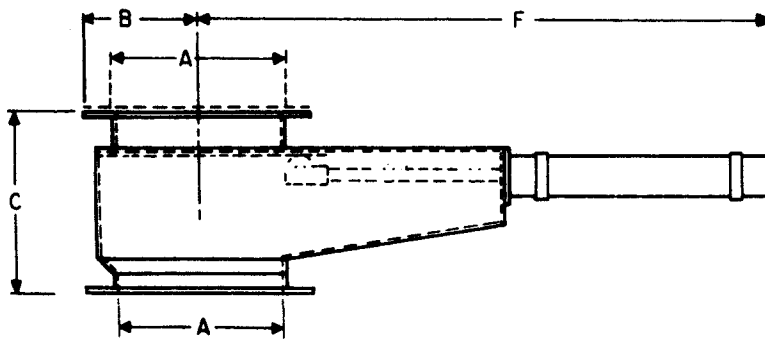

Screw Diam.	A	B	C	D	E	F	G	H	K
4	5	3-3/4	7-1/2	2-1/2	12	27	6	7	12
6	7	5	9	4	15-1/2	30	7-1/2	8	12
9	10	6-1/2	10	5	20	39-5/16	9	11	12
10	11	7-1/8	10-1/2	5	22	40-5/8	10	11-1/2	12
12	13	8-5/8	10-1/2	5	24-1/2	47-13/16	11-1/2	13	12
14	15	9-5/8	10-1/2	5-1/2	27-1/2	50-13/16	12-1/2	14	12
16	17	10-5/8	10-1/2	5-1/2	30-1/2	58-1/2	13-1/2	15	12
18	19	12-1/8	11-1/2	6-1/2	35	61-1/2	15	16-1/2	12
20	21	13-1/8	12	7	37	66-1/2	16	17-1/2	12
24	25	15-1/8	13	8	44	76-1/2	18	19-1/2	12

Screw Diam.	Trough Thick. ga.	Spout & Slide Thick. ga.	Part Number		Weight	
			Rack & Pinion	Pneumatic	Rack & Pinion	Pneumatic
4	14	14	RP 414 -FD*	PRP 414 -FD	27	34
	12	12	RP 412 -FD*	PRP 412 -FD	32	52
6	14-12	14	RP 614 -FD*	PRP 614 -FD	42	63
	3/16	12	RP 612 -FD*	PRP 612 -FD	47	67
9	14-12-10	14	RP 914 -FD*	PRP 914 -FD	74	94
	3/16 - 1/4	10	RP 910 -FD*	PRP 910 -FD	81	101
10	14-12-10	14	RP 1014 -FD*	PRP 1014 -FD	84	105
	3/16 - 1/4	10	RP 1010 -FD*	PRP 1010 -FD	93	113
12	12-10	12	RP 1212 -FD*	PRP 1212 -FD	141	160
	3/16 - 1/4	3/16	RP 127 -FD*	PRP 127 -FD	158	176
14	12-10	12	RP 1412 -FD*	PRP 1412 -FD	160	185
	3/16 - 1/4	3/16	RP 147 -FD*	PRP 147 -FD	185	207
16	12-10	12	RP 1612 -FD*	PRP 1612 -FD	168	199
	3/16 - 1/4	3/16	RP 167 -FD*	PRP 167 -FD	197	225
18	12-10	12	RP 1812 -FD*	PRP 1812 -FD	240	269
	3/16 - 1/4	3/16	RP 187 -FD*	PRP 187 -FD	277	308
20	10	12	RP 2012 -FD*	PRP 2012 -FD	278	315
	3/16 - 1/4	3/16	RP 207 -FD*	PRP 207 -FD	318	353
24	10	12	RP 2412 -FD*	PRP 2412 -FD	350	389
	3/16 - 1/4	3/16	RP 247 -FD*	PRP 247 -FD	402	438

* Handwheel supplied as standard assembly
 -C Chain wheel
 -R Rope wheel

Note: For Bolt pattern see page 65.

DISCHARGE GATES



dust tight rack and pinion curved slide

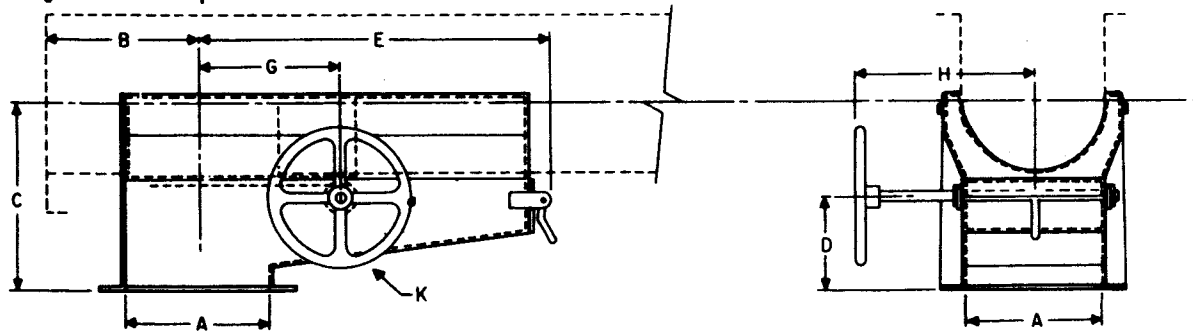

dust tight pneumatic curved slide

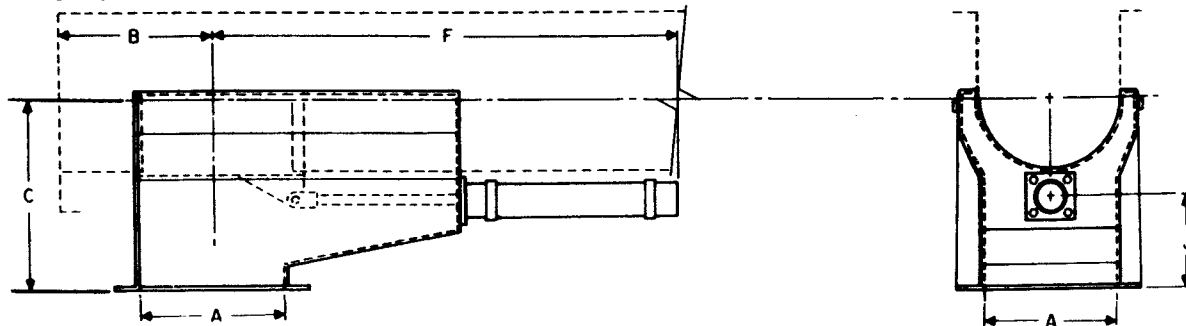

Screw Diam.	A	B Minimum	C	D	E	F	G	H	J	K
4	5	4-1/2	7-1/2	2-1/2	12	25-1/2	6	7	2	12
6	7	6	10	4	15-1/2	28-1/2	7-1/2	8	3-1/2	12
9	10	8	12-1/2	5	20	37-13/16	9	11	4-1/2	12
10	11	9	13	5	22	39-5/16	10	11-1/2	4-1/2	12
12	13	10-1/2	15	5	24-1/2	46-5/16	11-1/2	13	4-1/2	12
14	15	11-1/2	15-1/2	5-1/2	27-1/2	49-5/16	12-1/2	14	5-1/2	12
16	17	13-1/2	16-1/2	5-1/2	30-1/2	57	13-1/2	15	5-1/2	12
18	19	14-1/2	18-1/2	6-1/2	35	60	15	16-1/2	6-1/2	12
20	21	15-1/2	20	7	37	65	16	17-1/2	7	12
24	25	17-1/2	23	8	44	75	18	19-1/2	8	12

Screw Diam.	Trough Thick. ga.	Spout & Slide Thick. ga.	Part Number		Weight	
			Rack & Pinion	Pneumatic	Rack & Pinion	Pneumatic
4	14	14	RP 414 -CD*	PRP 414 -CD	30	37
			RP 412 -CD*	PRP 412 -CD	35	57
6	14-12 3/16	14	RP 614 -CD*	PRP 614 -CD	46	69
			PR 612 -CD*	PRP 612 -CD	52	74
9	14-12-10 3/16 - 1/4	14	RP 914 -CD*	PRP 914 -CD	81	103
			RP 910 -CD*	PRP 910 -CD	89	111
10	14-12-10 3/16 - 1/4	14	RP 1014 -CD*	PRP 1014 -CD	92	115
			RP 1010 -CD*	PRP 1010 -CD	102	124
12	12-10 3/16 - 1/4	12	RP 1212 -CD*	PRP 1212 -CD	155	176
			RP 127 -CD*	PRP 127 -CD	174	194
14	12-10 3/16 - 1/4	12	RP 1412 -CD*	PRP 1412 -CD	176	204
			RP 147 -CD*	PRP 147 -CD	204	228
16	12-10 3/16 - 1/4	12	RP 1612 -CD*	PRP 1612 -CD	185	219
			RP 167 -CD*	PRP 167 -CD	217	248
18	12-10 3/16 - 1/4	12	RP 1812 -CD*	PRP 1812 -CD	264	296
			RP 187 -CD*	PRP 187 -CD	305	339
20	10 3/16 - 1/4	12	RP 2012 -CD*	PRP 2012 -CD	306	347
			RP 207 -CD*	PRP 207 -CD	350	388
24	10 3/16 - 1/4	12	RP 2412 -CD*	PRP 2412 -CD	385	428
			RP 247 -CD*	PRP 247 -CD	442	482

* Handwheel supplied as standard assembly
 -C Chain wheel
 -R Rope wheel

Note: For Bolt pattern see page 65.

TROUGH COVERS



▲ Semi-Flanged Cover with Spring Clamp

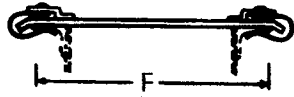

Type 1.

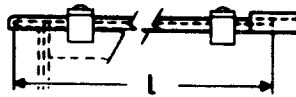

Type 2.

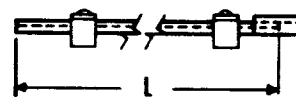

Type 3.

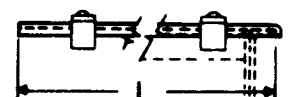

Flanged cover

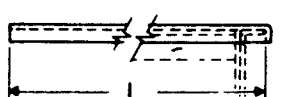
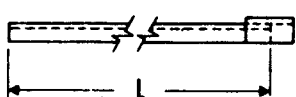
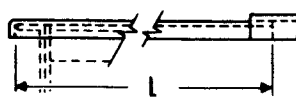
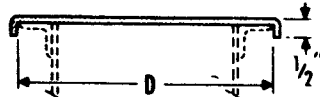

Dust seal cover

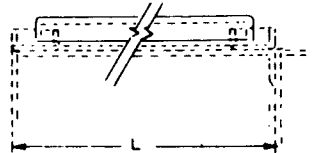
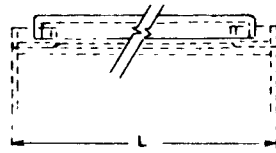
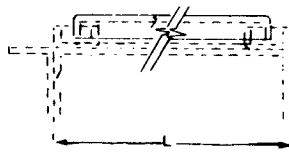
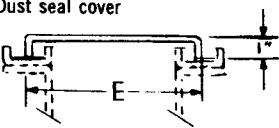

Ridged cover

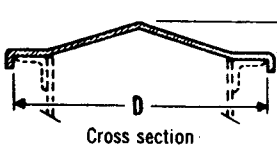

Cross section

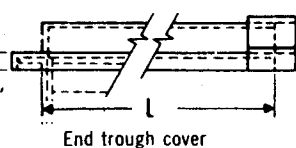

End trough cover

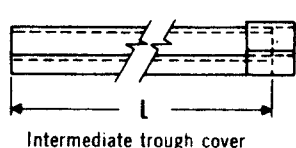

Intermediate trough cover

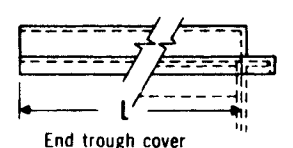

End trough cover

Flared trough cover

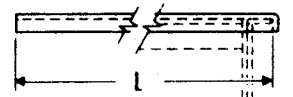
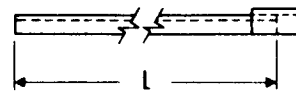
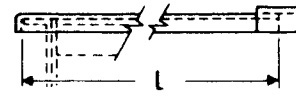
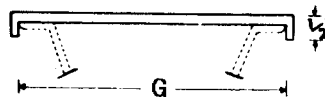

Conveyor Diam.	Semi-Flanged Cover			Flanged Cover		Dust Seal Cover		Ridged Cover		Flared Cover		D	E	F	G
	Part Number	Thickness ga.	Wt. per Ft.	Part Number	Wt. per Ft.	Part Number	Wt. per Ft.	Part Number	Wt. per Ft.	Part Number	Wt. per Ft.				
4	TC 414-S	14	2.1	TC 414-F	2.9	TC 414-D	3.0	TC 414-R	3.0	—	—	7-7/8	6	8-1/2	—
6	TC 614-S	14	4.8	TC 614-F	3.6	TC 614-D	3.8	TC 614-R	3.8	TC 614-V	4.8	9-7/8	8-1/4	10-1/2	17-3/8
9	TC 914-S	14	3.7	TC 914-F	4.5	TC 914-D	4.5	TC 914-R	4.5	TC 914-V	6.3	13-7/8	11-1/2	14-1/2	22
10	TC1014-S	14	3.9	TC1014-F	4.9	TC1014-D	5.0	TC1014-R	5.0	—	—	14-7/8	12-1/2	15-1/2	—
12	TC1214-S	14	4.6	TC1214-F	4.4	TC1214-D	4.4	TC1214-R	4.4	TC1214-V	7.4	17-1/2	15	18-1/4	27
	TC1212-S	12	6.4	TC1212-F	6.2	TC1212-D	6.2	TC1212-R	6.2	TC1212-V	9.8				
14	TC1414-S	14	5.1	TC1414-F	5.0	TC1414-D	5.0	TC1414-R	5.0	TC1414-V	7.9	19-1/2	17	20-1/4	29
	TC1412-S	12	7.1	TC1412-F	7.0	TC1412-D	7.0	TC1412-R	7.0	TC1412-V	10.5				
16	TC1614-S	14	5.6	TC1614-F	5.5	TC1614-D	5.6	TC1614-R	5.6	TC1614-V	9.0	21-1/2	19	22-1/4	33
	TC1612-S	12	7.9	TC1612-F	7.7	TC1612-D	7.8	TC1612-R	7.8	TC1612-V	12.0				
18	TC1814-S	14	6.4	TC1814-F	6.2	TC1814-D	6.2	TC1814-R	6.2	TC1814-V	10.4	24-1/2	21-1/2	25-1/4	37
	TC1812-S	12	8.9	TC1812-F	8.7	TC1812-D	8.7	TC1812-R	8.7	TC1812-V	13.4				
20	TC2014-S	14	6.9	TC2014-F	6.5	TC2014-D	6.6	TC2014-R	6.6	TC2014-V	11.3	26-1/2	23-1/2	27-1/2	40
	TC2012-S	12	9.7	TC2012-F	9.1	TC2012-D	9.2	TC2012-R	9.2	TC2012-V	15.0				
24	TC2414-S	14	8.0	TC2414-F	7.2	TC2414-D	7.2	TC2414-R	7.2	TC2414-V	11.3	30-1/2	27-1/2	31-1/4	46
	TC2412-S	12	11.2	TC2412-F	10.1	TC2412-D	10.1	TC2412-R	10.1	TC2412-V	17.0				

For average applications where dust confinement is not a problem, 2'-0" centers of 10 fasteners per 10'-0" section are generally satisfactory. For commercial dust tight 1'-0" centers or 20 fasteners per 10'-0" section are suggested.

- ▲ Standard Spring Clamp Cover has clips every 2'-0" centers
- Standard gauge.

TROUGH COVER ACCESSORIES



FLANGED CONVEYOR INLETS

The two styles of flanged conveyor inlets are designed for either bolting or welding to flat or flanged conveyor through cover. The inlet size and bolt arrangement is the same as the standard conveyor discharge spout.

FIXED TYPE

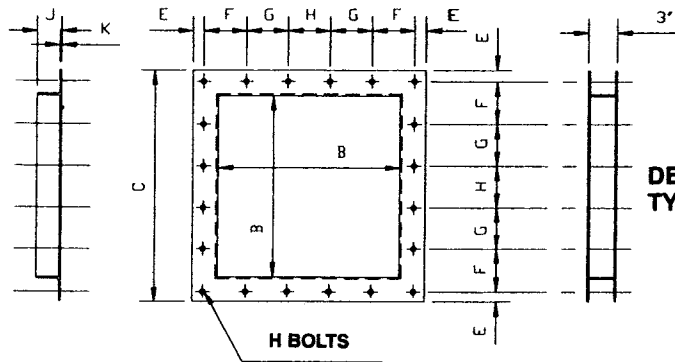

DETACHABLE TYPE

Conv Diam	Part Number		Weight	B	C		E		F	G	H	J	K	N
	Fixed Inlet	Detachable Inlet			Fixed Inlet	Detachable Inlet	Fixed Inlet	Detachable Inlet						
4	FCI 4	FCI 4-D	1.8	5	7-1/2	7-1/2	3/8	3/8	2-1/4	—	2-1/4	1-1/4	1/8	1/4
6	FCI 6	FCI 6-D	5.0	7	10	10	11/16	11/16	2-13/16	—	3	1-1/2	3/16	3/8
9	FCI 9	FCI 9-D	6.8	10	13	13	1/2	1/2	4	—	4	1-1/2	3/16	3/8
10	FCI10	FCI10-D	7.4	11	14	14-1/4	1/2	5/8	4-5/16	—	4-3/8	1-1/2	3/16	3/8
12	FCI12	FCI12-D	12.1	13	17	17-1/4	3/4	7/8	5-1/8	—	5-1/4	2	3/16	3/8
14	FCI14	FCI14-D	13.7	15	19	19-1/4	3/4	7/8	3-1/2	3-1/2	3-1/2	2	3/16	3/8
16	FCI16	FCI16-D	15.3	17	21	21-1/4	3/4	7/8	3-3/4	4	4	2	1/4	3/8
18	FCI18	FCI18-D	29.0	19	24	24-1/4	1	1-1/8	4-7/16	4-3/8	4-3/8	2-1/2	1/4	1/2
20	FCI20	FCI20-D	31.8	21	26	26-1/4	1	1-1/8	4-7/8	4-3/4	4-3/4	2-1/2	1/4	1/2
24	FCI24	FCI24-D	37.2	25	30	30-1/4	1	1-1/8	5-5/8	5-5/8	5-1/2	2-1/2	1/4	1/2

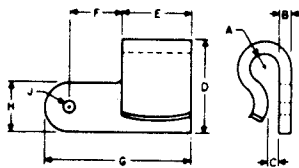

SPRING CLAMPS

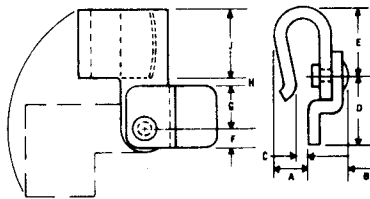

SPRING CLAMPS WITH BRACKETS

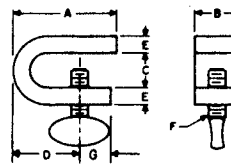

SCREW CLAMPS

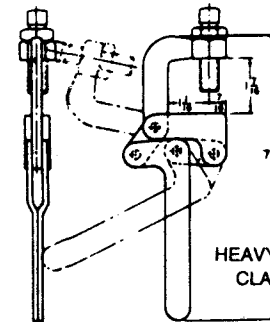

HEAVY DUTY CLAMPS

SPRING CLAMPS are normally used for attaching flat or semi-flanged covers to conveyor troughs. The clamps are riveted to the trough and will pivot to permit removal of cover.

SPRING CLAMPS WITH BRACKETS are attached to the top side of semiflanged covers. Plain spring.

SCREW CLAMPS are designed especially for attaching flanged cover to conveyor troughs, but can also be used for attaching flat or semi-flanged covers.

HEAVY-DUTY CLAMPS are ordinarily used for drop bottom screw conveyor troughs. Another popular application is for trough covers and panels that require easy access and tight seals.

SPRING CLAMP

Clamp No.	A	B	C	D	E	F	G	H	J
SC-S1	7/16	3/16	1/4	2	1-7/16	1-1/4	3-1/8	1-1/16	1/4

SPRING CLAMP WITH COVER BRACKET

Clamp No.	A	B	C	D	E	F	G	H	J
SC-SB	11/16	3/8	3/16	2-1/4	2-5/8	3/4	1/2	5/8	1-7/16

SCREW CLAMP

Clamp No.	A	B	C	D	E	F	G	Wt.
SC-C1	2-1/2	1	1-1/4	2-1/8	3/8	3/8	3/8	.48

BOLT PATTERNS



U-Trough End Flanges

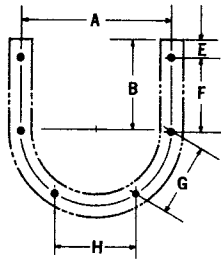

6 Bolts

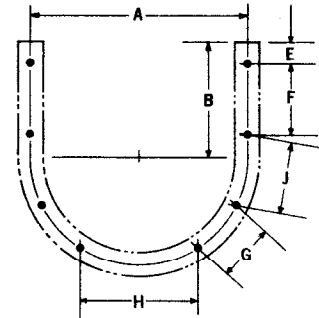

8 Bolts

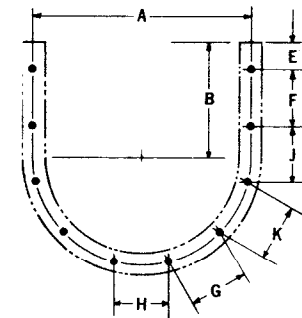

10 Bolts

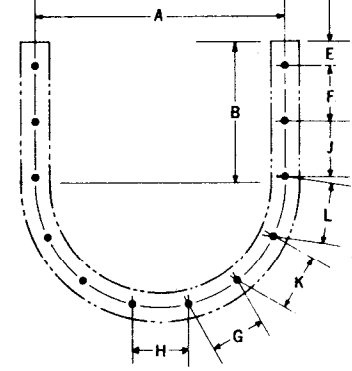

12 Bolts

Screw Dia.	Bolts		A	B	E	F	G	H	J	K	L
	No.	Dia.									
4	6	3/8	7	3-5/8	1-1/8	3-1/8	3-1/8	3-1/8	x	x	x
6	6	3/8	8-7/8	4-1/2	1-1/32	4-1/8	4-1/16	4-1/16	x	x	x
9	8	3/8	12-1/2	6-1/8	1-3/16	4-1/8	3-3/4	5-1/8	4-1/8	x	x
10	8	3/8	13-1/4	6-3/8	2-1/4	3-1/2	4-3/16	5-1/16	4-1/8	x	x
12	8	1/2	15-7/8	7-3/4	1-1/2	5-5/16	4-1/16	7-3/4	5-3/16	x	x
14	8	1/2	17-7/8	9-1/4	2-17/32	5-5/8	5-15/16	6	5-15/16	x	x
16	8	5/8	20	10-5/8	2-5/8	6-3/8	6-5/8	7-1/2	6-5/8	x	x
18	10	5/8	22	12-1/8	2-23/32	5-15/16	5-7/8	5-7/8	5-7/8	5-7/8	x
20	10	5/8	24-3/8	13-1/2	2-25/32	6-1/4	6-11/16	6-11/16	6-11/16	6-11/16	x
24	12	5/8	28-1/2	16-1/2	2-25/32	6-1/8	6-5/8	6-5/8	6-5/8	6-5/8	6-5/8

Flared Trough End Flanges

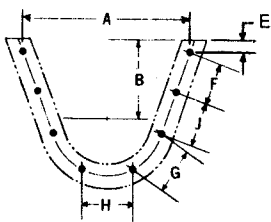

8 Bolts

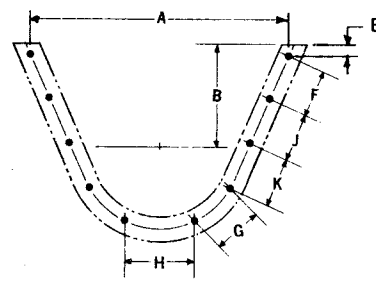

10 Bolts

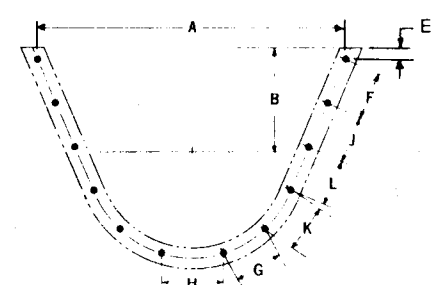

12 Bolts

Screw Dia.	Bolts		A	B	E	F	G	H	J	K	L
	No.	Dia.									
6	6	3/8	14-3/8	7	1-27/32	5-1/4	5-1/4	4-1/16	—	—	—
9	8	3/8	19-5/16	9	1-43/64	5	5	5-1/8	5	—	—
12	8	1/2	23-5/8	10	1-13/16	5-3/4	5-3/4	7-3/4	5-3/4	—	—
14	10	1/2	25-17/32	11	2-1/16	5-1/8	5-1/8	6	5-1/8	5-1/8	—
16	10	5/8	29-3/8	11-1/2	2-15/64	5-1/2	5-1/2	7-1/2	5-1/2	5-1/2	—
18	10	5/8	32	12-1/8	2-5/8	6-3/16	6-3/16	5-7/8	6-3/16	6-3/16	—
20	10	5/8	35-3/4	13-1/2	2-9/32	7	7	6-11/16	7	7	—
24	12	5/8	41-29/32	16-1/2	2-5/16	6-7/8	6-7/8	6-5/8	6-7/8	6-7/8	6-7/8

BOLT PATTERNS



TUBULAR HOUSING FLANGES

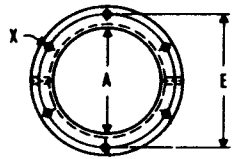

6 bolts

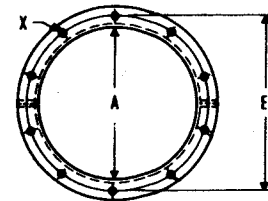

10 bolts

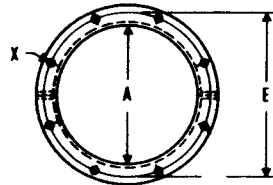

8 bolts

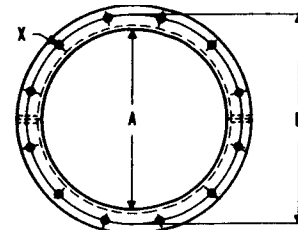

12 bolts

INTAKE & DISCHARGE FLANGES

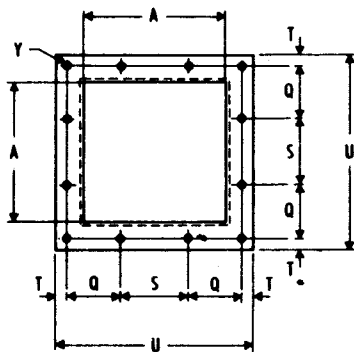

12 bolts

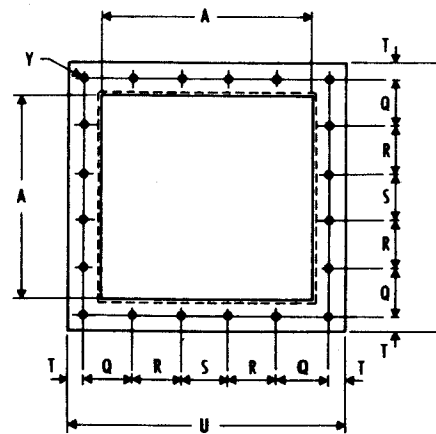

20 bolts

Screw Size	Flange Bolts		A	E	Q	R	S	T	U
	Tubular x	Discharge y							
4	6-3/8	12-1/4	5	7	2-1/4	—	2-1/4	3/8	7-1/2
6	6-3/8	12-3/8	7	8-7/8	2-13/16	—	3	11/16	10
9	8-3/8	12-3/8	10	12-1/2	4	—	4	1/2	13
10	8-3/8	12-3/8	11	13-1/4	4-5/16	—	4-3/8	5/8	14-1/4
12	8-1/2	12-3/8	13	15-7/8	5-1/8	—	5-1/4	7/8	17-1/4
14	8-1/2	20-3/8	15	17-7/8	3-1/2	3-1/2	3-1/2	7/8	19-1/4
16	8-5/8	20-3/8	17	20	3-3/4	4	4	7/8	21-1/4
18	10-5/8	20-1/2	19	22	4-7/16	4-3/8	4-3/8	1-1/8	24-1/4
20	10-5/8	20-1/2	21	24-3/8	4-7/8	4-3/4	4-3/4	1-1/8	26-1/4
24	12-5/8	20-1/2	25	28-1/2	5-5/8	5-5/8	5-1/2	1-1/8	30-1/4

Safety

Installation and Maintenance Instructions

⚠ WARNING



**Lock out power
before removing
cover or guard.**

**Do not step on
cover or guard.**

CAUTION

GUARDS, ACCESS DOORS AND COVERS MUST BE SECURELY FASTENED BEFORE OPERATING THIS EQUIPMENT. LOCK OUT POWER BEFORE REMOVING GUARDS, ACCESS DOORS AND COVERS. FAILURE TO FOLLOW THESE INSTRUCTIONS MAY RESULT IN PERSONAL INJURY OR PROPERTY DAMAGE.

WARNING—IMPORTANT INFORMATION CONTAINED IN THIS BULLETIN—TO BE REVIEWED AND FOLLOWED BY CONTRACTOR, INSTALLER, OWNER AND OPERATOR.

GENERAL

All standard screw conveyor components are manufactured in conformity with CEMA standards. Special components are designed and manufactured to the particular job specifications.

Screw conveyors may be ordered either as complete units or by individual components. Complete units are normally shop assembled and then match marked and disassembled for shipment and field re-assembly. When components only are ordered, shipment is made as ordered and these components must be

sorted out and aligned in field assembly.

Because shop assembled screw conveyors are pre-aligned and match marked at the factory, they are easier to assemble in the field and require minimum installation time. When individual components are ordered, more careful alignment and assembly are required. More time is required for field installation. Assembly bolts are not included with parts orders unless specified, but are included with preassembled units.

HAZARDOUS OPERATION

Screw conveyors are not normally manufactured or designed to operate handling hazardous material or in a hazardous environment.

Hazardous materials can be those that are explosive, flammable, toxic or otherwise dangerous to personnel if they are not completely and thoroughly contained

in the conveyor housing. Special construction of screw, and conveyor housing with gaskets and special bolted covers can sometimes be used for handling this type of material.

Screw conveyors are not made or designed to comply with local, state, or federal codes for unfired pressure vessels.

SAFETY

All screw conveyors shop assembled by Conveyors, Inc. have warning labels affixed in many easily seen locations. All warning labels must be kept clean of debris for good visibility. If the equipment exterior is painted, coated or altered in any way or if the material conveyed is in excess of 175°, additional warning labels are available upon request by calling (817) 473-4645.

Most accidents are the result of someone's carelessness or negligence. In order to avoid an unsafe or hazardous condition, the conveyor assemblies, or parts must be installed with the following minimum provisions:

1) Screw conveyors shall not be operated unless the conveyor housing completely encloses the conveyor moving elements and power transmission guards are in place. If the conveyor is to be opened for inspection, cleaning, or observation, the motor driving the conveyor is to be locked out electrically in such a manner that it cannot be restarted by anyone, however remote from the area, unless the conveyor housing has been closed, and all other guards are in place.

2) If the conveyor must have an open housing as a condition of its use and application, the entire conveyor is then to be guarded by a railing or fence.

3) Feed openings for shovel, front-end loader or other manual or mechanical equipment shall be constructed in such a way that the conveyor screw is covered by grating. If the nature of the material is such that a grating cannot be used, then the exposed section of the conveyor is to be guarded by a railing and there shall be warning signs posted.

4) Do not walk on conveyor covers or gratings or power transmission guards.

5) Do not poke or prod material in the conveyor opening.

6) Do not place hands or feet in any conveyor opening.

7) Do not overload conveyor or use it for anything but its intended use.

8) Practice good housekeeping.

9) Employer/Owner is responsible for training operator in safe operation or screw conveyors.

Conveyors, Inc. can assist in the selection and design of special devices or equipment that will aid the owner and installer in preparing a safe installation and a safe working place. For information call (817) 473-4645.

1) Overflow devices consisting of a hinged door connected to a limit switch can be arranged to shut off conveyor power when discharge of the conveyor is interrupted or plugged and full.

2) Zero speed switches can be arranged to shut off power in the event the conveyor is stopped due to the presence of foreign material or if for some reason the drive end of the conveyor is still running while the opposite end has stopped.

There are many kinds of electrical interlocking of conveyors and conveyor systems such that if one conveyor in a system or process is stopped, other equipment feeding it or following it can also be automatically stopped.

There are also many ways to insure that a conveyor will not run unless the housing and guards are all in place. For such electrical control devices and circuit design, consult your electrical supplier.

Screw conveyor inlet and discharge openings are designed to connect to other equipment or machinery so that the flow of material into and out of the conveyor is completely enclosed.

CAUTION

Do not use screw conveyors until instructed in the safe operation by a competent safety engineer. All conveyors can be dangerous if improperly used. For additional information see the Williams-Steiger Occupational Safety and Health Act and the American National Standard Institute Safety Code.

INSTALLATION

RECEIVING

Check all assemblies or parts with shipping papers and inspect for damage. Specifically check for dented or bent trough, bent flanges, bent flighting, bent pipe or hangers, or damaged bearings. If any components are severely damaged in shipment, claims should be filed immediately with the carrier.

For shop assembled conveyors, units are match marked, and shipped in longest sections practical for shipment. Field assembly can be accomplished by connecting match marked joints and in accordance with packing list and/or drawing if applicable. In field erection, the mounting surfaces for supporting the conveyor must be level and true so there is no distortion in the conveyor. Shims or grout should be used when required. Check for straightness as assembly is made.

For conveyor assemblies purchased as parts or merchandise, assemble as follows: place conveyor troughs in proper sequence with inlet and discharge spout properly located. Connect the trough flanges loosely. Do not tighten bolts. Align the trough bottom centerlines perfectly using piano wire (or equivalent) then tighten flange bolts. Tighten all anchor bolts.

Assembly of conveyor screws should always begin at the thrust end. If the unit does not require a thrust unit, assembly should begin at the drive end. If a thrust end is designated, assemble trough end and thrust bearing. Insert the end or drive shaft in the end bearing. Do not tighten set screws until conveyor assembly is completed.

Place the first screw section in the trough, slipping the end or drive shaft into the pipe end. Secure tightly with coupling bolts. Install so that conveyor end lugs are opposite the carrying side of the flight.

Place a coupling shaft into the opposite end of conveyor pipe. Tighten coupling bolts.

Insert coupling shaft into hanger bearing and clamp hanger to trough.

Assemble alternately, conveyor screws, couplings and hangers until all screws are installed.

1) With Hangers: Assemble screw section so that flighting at each end is approximately 180 degrees from ends of flighting of adjacent sections. Also, adjust conveyor screw and thrust unit so that hangers are equally spaced between adjacent screws.

2) Without hangers: (Close Coupled) Assemble screws so that flighting at adjoining ends of screw sections align to produce a continuous helix surface. (Note coupling holes have been drilled in assembly to allow for flight alignment.)

Remove hanger clamps and bolt hanger to trough with the bearing centered between conveyor screws.

Install trough covers in proper sequence. Properly locate inlet openings. Handle covers with reasonable care to avoid warping or bending.

Attach covers to trough with fasteners provided.

Check screw rotation for proper direction of material travel after electrical connections have been made, but before attempting to handle material. Incorrect screw rotation can result in serious damage to the conveyor and to related conveying and drive equipment.

If necessary, reconnect electrical leads to reverse rotation of conveyor and direction of material flow.

OPERATION

Lubricate all bearings and drives per service instructions. Gear reducers are normally shipped without lubricant. Refer to service instructions for lubrication.

In start-up of the conveyor, operate several hours empty as a break-in period. Observe for bearing heat up, unusual noises or drive misalignment. Should any of these occur, check the following and take necessary corrective steps. (Non-lubricated hanger bearings may cause some noise.)

1) When anti-friction bearings are used, check for proper lubrication. Insufficient or excess lubricant will cause high operating temperatures.

2) Misalignment of trough ends, screws, hangers and trough end can cause excessive maintenance and poor life expectancy.

3) Check assembly and mounting bolts; tighten if necessary.

Do not overload conveyor. Do not exceed conveyor speed, capacity, material density, or rate of flow for which the conveyor and drive were designed.

If the conveyor is to be inoperative for a prolonged period of time, operate conveyor until cleared of all material. This is particularly important when the material conveyed tends to harden or become more viscous, or sticky, if allowed to stand for a period of time.

It may be necessary to recenter hanger bearings after running material in conveyor.

MAINTENANCE

Practice good housekeeping. Keep the area around the conveyor and drive clean and free of obstacles to provide easy access and to avoid interference with the function of the conveyor and drive.

Establish routine periodic inspections of the entire conveyor to insure continuous maximum operating performance.

To replace conveyor screw section, proceed as follows:

1) Removal of a section, or sections, usually must proceed from the end opposite the drive. Make sure drive and electrical power are disconnected before starting to disassemble.

2) Remove the trough end, sections of screws, coup-

ling shafts, and hangers until all sections have been removed, or until the damaged or worn section is reached and removed.

3) To reassemble, follow the above steps in reverse order.

4) Quick-removable conveyor screws can be removed at intermediate locations without first removing adjacent sections.

Replacement parts can be identified from a copy of the original packing list or invoice.

The coupling bolt contains a lock nut that may become damaged when removed. It is recommended practice to replace lock nuts rather than re-use them when changing conveyor screw sections.

WARRANTY

Conveyors, Inc. shall not be liable for damages or delays caused by defective material or workmanship, and it is agreed that the liability of Conveyors, Inc. under all guarantees, either express or implied, is specifically limited to the replacement, free of charge, F.O.B. its factory, of parts failing through defective workmanship or materials within 12 months after delivery thereof to the original purchaser and in the manner aforesaid. No allowances for repairs will be considered unless Conveyors, Inc. has given advance authorization of such repairs or alterations in writing.

Screw Layout / Hand of Conveyor

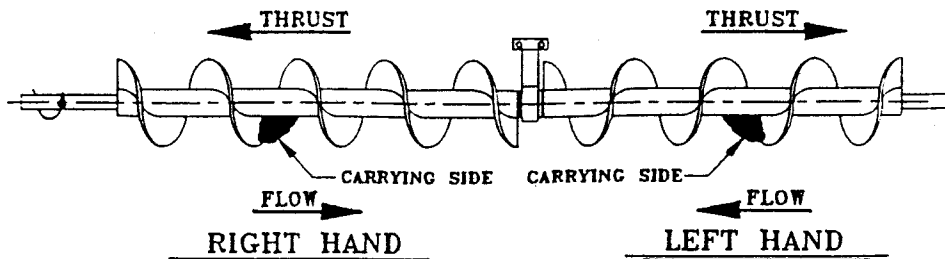
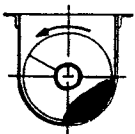
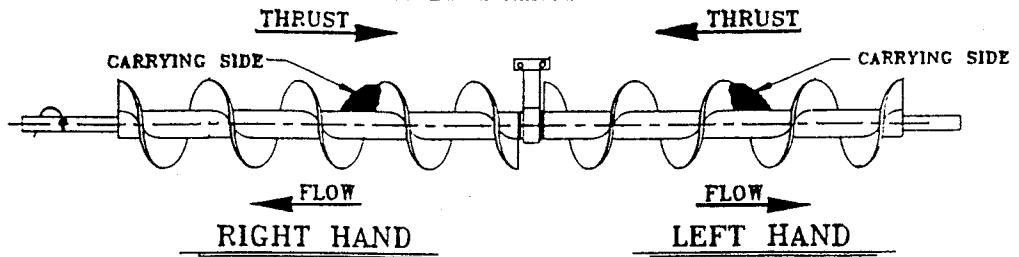
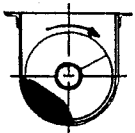
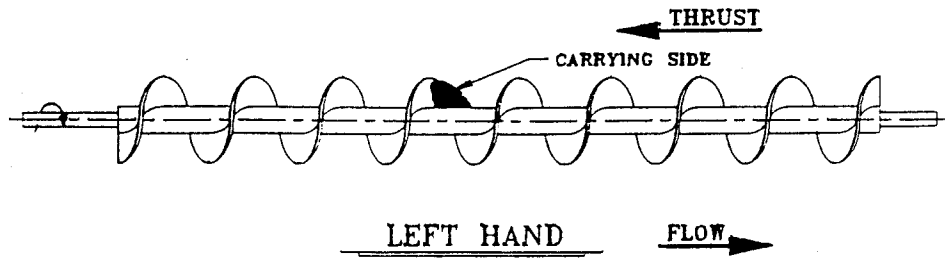
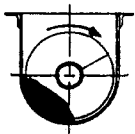
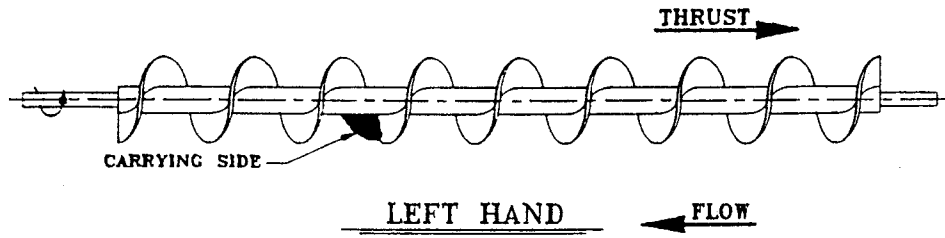
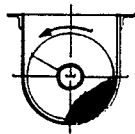
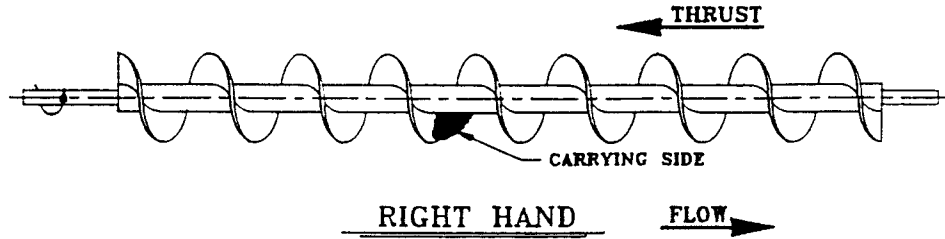
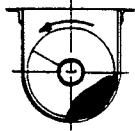
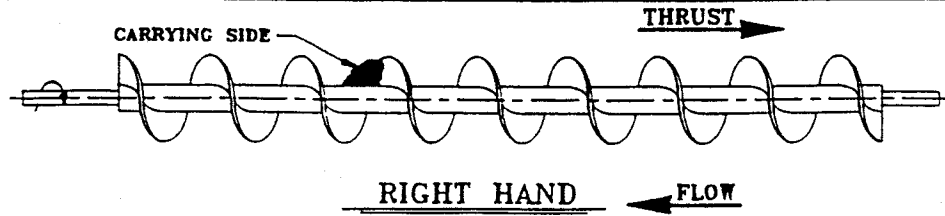
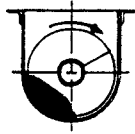
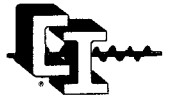

Required design information for screw conveyors:

1. Product being conveyed _____
2. Weight per cubic foot _____
3. Temperature of the product _____
4. Maximum lump size _____
5. Capacity of the conveyor (cubic feet per hour, tons per hour, etc.) _____
6. Length (inlet-to-discharge or overall length) _____
7. Horizontal or inclined?
8. If inclined, _____ deg.
9. How is the conveyor fed? (controlled/uniformly fed or flood fed)
10. If flood fed, what is the size of the inlet and height of product above the inlet at startup?
11. Conveyor will run _____ hrs. per day.
12. Material of construction (mild steel, type of stainless, etc.) _____
13. Customer preferences regarding diameter, thickness, etc. _____
14. Special paint (mild steel) or special finish (if stainless) _____
15. Shop assemble the conveyor or ship as parts only?
16. Will the drive be furnished by C.I. or others?
17. If furnished by CI are there any special motor and/or drive requirements?
18. If furnished by others will the drive be sent to CI for mounting and test run?

Screw Conveyor Layout

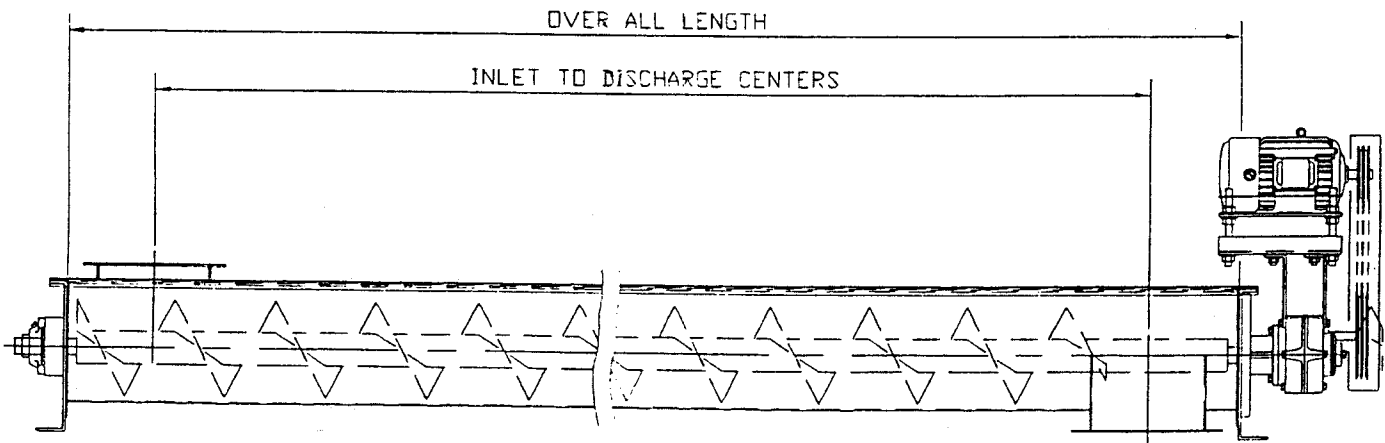

CONVEYORS INCORPORATED

P.O. BOX 50817

FORT WORTH, TEXAS 76105

PHONE 817/477-3151

PHONE 817/473-4645

FAX # 817/473-3024

www.conveyorsinc.net

Email: sales@conveyorsinc.net